

# Hand Pump Repair

A Technician Training Manual

**First Edition**  
January 2010

**Authors**  
Fred Proby  
Scott Koontz



## Our Mission

We are Christians providing access to safe water, and improved sanitation and hygiene, one village at a time.

## Our Vision

Safe water for every child. A healthy home for every family. The love of Christ for all.



## Hand Pump Repair: A Technician Training Manual

Revised January 2010

Lifewater, Inc. (dba Lifewater International) is a Christian development organization dedicated to effectively and sustainably partnering with communities for integrated water, sanitation, and hygiene solutions. Lifewater International is a 501(c)(3) non-profit that intentionally serves all people regardless of race, religion, ethnicity, or gender.

### Copyright

This training material is published by Lifewater, Inc. under the open content copyright provisions and its license is available under the Creative Commons Attribution-Noncommercial-Share Alike 3.0 United States License on the website: <http://creativecommons.org/licenses/by-nc-sa/3.0/> -or through sending a letter to Creative Commons, 171 Second Street, Suite 300, San Francisco, California, 94105 USA.

### Attribution Non-Commercial Share Alike

#### **You are free:**

1. *To Share* - copy, distribute and transmit the work
2. *To Remix* - to adapt and/or translate the work

#### **Under the following conditions:**

1. Attribution - you must maintain Lifewater's name branding in the footer for all new creations and/or derivatives (but not indicate Lifewater's endorsement of you or your use of the work, unless specified in a partnership agreement)
2. Non-commercial - you may not use this work for commercial purposes
3. Share-alike - if you alter, transform, or build upon this work, you may distribute the resulting work only under the same or similar license as this one

As part of its charitable mission to make clean water accessible, Lifewater has agreed to share these materials free of charge for non-commercial use. These materials are provided on a "**AS IS**" and "**AS AVAILABLE**" basis. TO THE FULLEST EXTENT PERMISSIBLE PURSUANT TO APPLICABLE LAW, LIFEWATER DISCLAIMS ALL WARRANTIES, EXPRESS OR IMPLIED, INCLUDING WARRANTIES OF TITLE, MERCHANTABILITY, NON-INTERFERENCE, SUITABILITY, FITNESS FOR A PARTICULAR PURPOSE, ACCURACY, COMPLETENESS, AVAILABILITY, SECURITY, COMPATIBILITY, AND NONINFRINGEMENT, AND WARRANTIES ARISING FROM COURSE OF PERFORMANCE, COURSE OF DEALING OR TRADE USAGE.

You are responsible for the proper use of these materials. By accepting these materials, you agree to indemnify, defend, and hold harmless, Lifewater, its agents, and affiliates from and against any and all losses, damages, liabilities, and costs, including costs and expenses incurred to defend any action or threatened action associated with or related to your use of these materials.

UNDER NO CIRCUMSTANCES, INCLUDING NEGLIGENCE, SHALL LIFEWATER, ITS AGENTS, OR AFFILIATES BE LIABLE TO YOU OR ANY OTHER PERSON OR ENTITY FOR ANY INDIRECT, INCIDENTAL, SPECIAL, OR CONSEQUENTIAL DAMAGES INCLUDING LOST PROFITS, BUSINESS INTERRUPTION, LOST DATA, PERSONAL INJURY



(INCLUDING DEATH), AND PROPERTY DAMAGE OF ANY NATURE WHATSOEVER, THAT RESULT FROM THE USE OF, OR THE INABILITY TO USE, ITS CONTENT. IN NO EVENT SHALL OUR TOTAL LIABILITY TO YOU FOR ALL DAMAGES, LOSSES, AND CAUSES OF ACTION WHETHER IN CONTRACT, TORT (INCLUDING NEGLIGENCE) OR OTHERWISE EXCEED THE AMOUNT PAID BY YOU, IF ANY, OR \$10 (WHICHEVER IS LESS) FOR ACCESSING OR USING OUR CONTENT OR SERVICES.

These terms shall be construed in accordance with the laws of the state of Arkansas, without regard to conflict of laws principles. You hereby consent to the jurisdiction of the courts in the State of Arkansas and agree to limit venue to the courts in Benton County, Arkansas.

Lifewater aims to maintain relationships with users of this work in order to learn from one another and obtain feedback on implementation. Therefore, organizations wanting to use this work are asked to sign a simple partnership agreement outlining specific terms of use. Please contact Lifewater International for more information:

**Lifewater International**

[www.lifewater.org](http://www.lifewater.org)

[info@lifewater.org](mailto:info@lifewater.org)

PO Box 2868

Bentonville, AR 72712

(805) 541-6634

## Purpose of this Manual

Like any other mechanical device, hand pumps wear out and break. The causes and the frequency of malfunction are affected by many variables. Keeping the pumps working – “hand pump sustainability” - is a critical problem with many facets. This manual has been written to address one of those facets, the shortage of trained pump repair technicians. It is primarily intended for use by Lifewater Field Trainers working with our partners to introduce them to the technical skills, knowledge, and attitudes that are considered necessary for a successful pump repair program. This manual is not a complete technical reference for specific pump models; that information is available from the pump manufacturers. Neither does it address in detail other key elements of sustainability such as the spare parts supply chain, methods of fostering community ownership, and government policies. Those subjects deserve separate treatment.

Ideally, this class will be taught in two sessions of one to two weeks each, with several months between sessions during which time the students are actively engaged in repairing hand pumps.



Lessons that can be studied individually at home.



Lessons that will work best in a classroom setting.



Lessons that are best taught at a pump repair site.

## Acknowledgements

The method of training in hand pump repair presented in this manual was developed by Troy Harper (then at Lifewater International), Jim Gehrels and Glenn Stronks (Lifewater Canada), and by Harry Westmoreland and Lew Hough (Living Water International). The saying regarding standing on others' shoulders certainly applies in this case. Contributions to this manual have also been made by Lifewater volunteers Tim Cleath, John Esch, Dwayne Lee, Kirk Schauer, Terry Steinhoff and Rod Thompson, and by Tearfund staff Neil Duguid and Morgan Palmer.

## Hand Pump Repair

### Table of Contents

<b>Section 1. Orientation</b>	<b>Page</b>
1.1 Welcome! .....	1
1.2 Course Objectives .....	3
1.3 Water: God’s Gift to Us .....	5
<hr/>	
<b>Section 2. Introduction to Hand Pumps</b>	
2.1 Proper Well Construction .....	11
2.2 Operational Principles of Hand Pumps .....	17
2.3 Common Pump Types .....	21
<hr/>	
<b>Section 3. Pump Repair Procedures</b>	
3.1 Tool Skills and Safety .....	27
3.2 The Four Laws of Pump Repair.....	31
3.3 Hand Pump Repair Procedures .....	33
3.4 Well Disinfection .....	39
3.5 Planning and Mobilization .....	43
3.6 Pump Repair Record.....	47
<hr/>	
<b>Section 4. Hand Pump Repair Exercises</b>	
4.1 The Afridev Hand Pump .....	57
4.2 Afridev Pump Cylinder .....	59
4.3 Afridev Adjustment .....	61
4.4 The India Mark II and Mark III Hand Pumps.....	65
4.5 Fishing.....	69
4.6 Cutting and Threading Steel Pipe .....	73
4.7 Cutting and Threading Pump Rod .....	77
4.8 Working With PVC Pipe .....	81
<hr/>	
<b>Section 5. Well Rehabilitation</b>	
5.1 Protecting the Well .....	85
5.2 Clearing an Obstructed Well .....	93
5.3 Well Closure .....	99
5.4 Upgrading a Hand-Dug Well .....	101
<hr/>	
<b>Section 6. More than Mechanics</b>	
6.1 Roles and Attitudes .....	103
6.2 Encouraging Village Water Committees.....	105
6.3 Hygiene and Sanitation .....	109
6.4 Safety Devotion and Daily Briefing.....	113
6.5 Daily Devotions.....	117

Appendices	Page
1. Pump Repair Tools .....	117
2. Well Disinfection Formulas.....	119
3. Hand Pump Repair Record .....	121
4. Well Cleanout tool Fabrication .....	123
5. Bailer Construction .....	127
6. Pump Repair Training Materials .....	129
7. Hand Pump Operation Depths .....	135
8. Mark II Installation & Maintenance Manual*.....	137
9. Afridev Installation & Maintenance Manual* .....	139

\*Optional: Provide manufacturer’s manuals appropriate to the location.

Tables	Page
1. Pump Performance Ratings.....	35
2. Well Disinfection.....	40
3. Hand Pump Repair Record .....	49
4. Schedule 40 PVC Strength Ratings.....	82
5. Metric & English uPVC Pipe Sizes .....	82

Figures	Page	Page	
1. Expectations Hand.....	2	23. De-burring Tool.....	74
2. The Water Cycle .....	8	24. Pipe Threader .....	75
3. Well Components.....	12	25. Pipe Wrap .....	76
4. Forcing Casing.....	14	26. Rod Clamp.....	77
5. Neglected Pump .....	18	27. Hack Saw.....	78
6. Pump Cylinder Operation.....	18	28. Rod Preparation.....	78
7. Cylinder Parts .....	19	29. Threading Tool Alignment .....	78
8. Cylinder Failure.....	20	30. Thread Quality .....	79
9. Suction Pump .....	22	31. Damaged Well .....	83
10. Direct Action Pump .....	22	32. Repaired Well .....	85
11. Deep Well Pumps .....	23	33. Mixing Concrete.....	86
12. Common Pump Repair Tools.....	28	34. Silted Casing.....	90
13. Right-Hand Rule.....	30	35. Rocks in Casing .....	91
14. Well Depth.....	40	36. Collapsed Casing.....	92
15. Broken Mark II.....	44	37. Well Cleanout Tool .....	94
16. Afridev Head.....	57	38. Well Closure.....	96
17. Afridev Cylinder.....	59	39. Hand-dug Well .....	98
18. Afridev Adjustment .....	63	40. Village Market.....	101
19. Mark II or III Head.....	65	41. Water Committee .....	102
20. Fishing Tools .....	70	42. Diarrhea Transmission .....	110
21. Pipe Vise .....	73	43. Tippy-Tap .....	111
22. Pipe Cutter.....	74	44. Head Injury .....	114







## Lesson 1.1 Welcome



### Purpose

*To get to know one another and reflect on the purpose of taking this class.*



### Objectives

*By the end of this lesson, participants will have*

- Briefly shared an experience which inspired them to work in pump repair;
- Become introduced to one another; and
- Illustrated and shared with one another their expectations for the class.



### Materials

- Name tags
- Paper and markers



### Preparation

- Organize the class into teams based on working groups or other relationships.
- If possible, include an experienced person in each team.
- Name tags should be numbered or color-coded to identify team membership.



### Time

30 minutes



### Steps

1. Introductions
2. Express Your Expectations



### 1. Introductions - 10 minutes

In order to get to know one another in a new way, take a few minutes to think of one significant event that led you to become involved in pump repair.

Then use a blank sheet of paper to draw a simple representation of that event. Write your name on the top of the paper and a short sentence about your event below the drawing. When you're finished, you can share the event with the class, if you wish.



### 2. Express Your Expectations - 20 minutes

Note the color of your name tag or number written on it; that is the team you will be working with throughout this class. Gather together with your team.

Working together with your team, draw an "expectations hand" similar to the one shown, and write on it some of your team's expectations for this class.

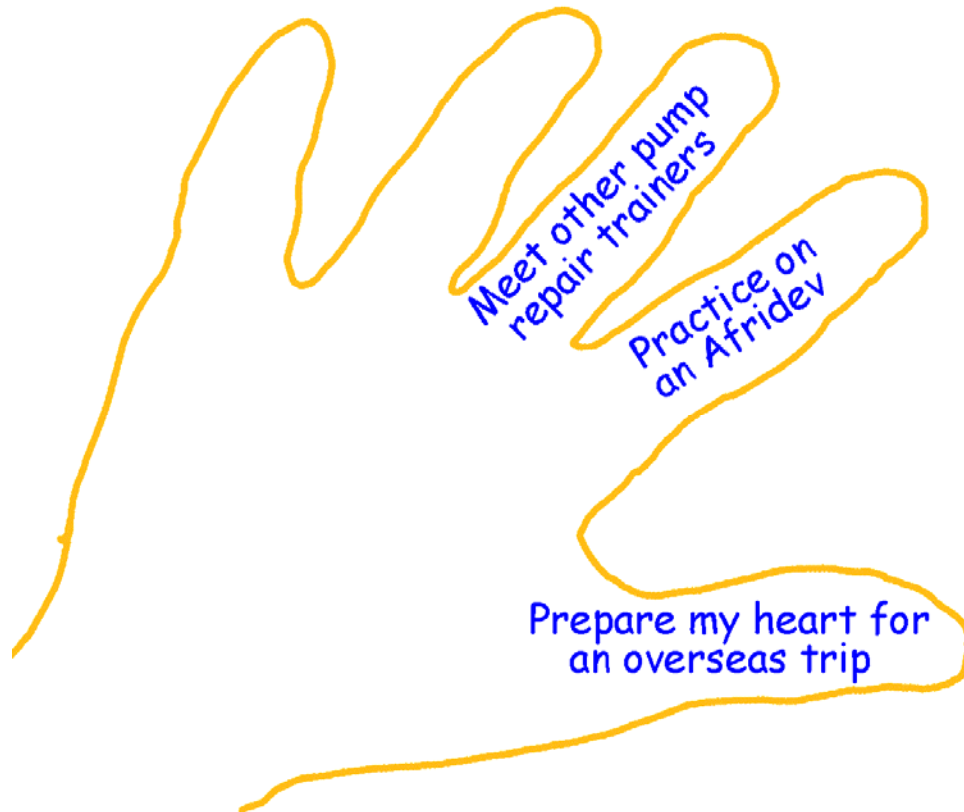







**Figure 1 Expectations Hand**

Post your team's hand on a wall with other teams' expectation hands. Read the other teams' expectations. We'll hear what stands out to you.



## Lesson 1.2 Course Objectives

	<b>Purpose</b> <i>To share the objectives of the course and understand the overall objectives of Lifewater as a Christian training organization.</i>
	<b>Objectives</b> <i>By the end of this lesson, participants will have</i> <ul style="list-style-type: none"><li>• Examined Lifewater's goals in the course.</li><li>• Read and commented on Lifewater's mission statement.</li></ul>
	<b>Materials</b> <ul style="list-style-type: none"><li>• None</li></ul>
	<b>Preparation</b> <ul style="list-style-type: none"><li>• Study lesson ahead of time.</li></ul>
	<b>Time</b> 20 minutes
	<b>Steps</b> <ol style="list-style-type: none"><li>1. Course Objectives</li><li>2. Lifewater's Mission Statement</li><li>3. Two Challenges</li></ol>

### 1. Course Objectives - 5 minutes

We know that you are eager to learn how to repair hand pumps. That is why we are all here! A great many hand pumps are in need of repair and this is a very cost-effective way to give a community a reliable water supply.

So we will spend a lot of time learning the mechanical details of the way hand pumps work, why they break, and how to fix them.

However, we are more than mechanics, aren't we? We are also ministers of the Gospel. That should make a difference in everything we do, from visiting with our neighbor to helping him fix his pump. So in this class we will also consider the attitudes we have and the way in which we conduct ourselves when working on a pump repair problem. Our work, as well as our lives, should be a reflection of God's character.

Another very important objective of this course is to keep you safe. There are many ways to get hurt in this class and while you are in the field working on a hand pump. So we will pay close attention to safe practices.

 **2. Lifewater's Mission Statement** - 10 minutes

In groups of two, read Lifewater's Mission Statement below and discuss any element that stands out to you. Be prepared to share your thoughts with the rest of the class.

**MISSION STATEMENT**

*"Compelled by God's call and the global water and sanitation crisis, Lifewater International equips partner organizations and works with them to empower communities in developing countries to gain safe water, adequate sanitation, effective hygiene, and the knowledge of Jesus' love."*

 **3. Two Challenges** - 5 minutes

Circumstances often exist that can be challenges for getting a job done. In pump repair, two common challenges are:

- **Parts Supply** - getting the parts you need for a particular pump.
- **Sustainability** - keeping the pump in working condition for a long time.

You will encounter circumstances such as government policies, community attitudes, and lack of parts which will be hard to overcome. As difficult as these problems may seem in comparison to your abilities, you can have an influence. God selected you for this work for a reason! You are problem-solvers who can contribute to a change in circumstances. Let God use the creativity that He has given you.



## Lesson 1.3 Water: God's Gift to Us



### Purpose

To introduce the water cycle, consider the impact of our use of water, and our responsibilities associated with that use.



### Objectives

By the end of this lesson, participants will have

- Reviewed a Biblical foundation for the need and provision of water in our lives.
- Considered where the water we use ends up.



### Materials

- Water Cycle poster
- Flipchart and markers



### Preparation

- Study lesson ahead of time.



### Time

60 minutes



### Steps

1. Uses for Water
2. Water in the Bible
3. God's Gift
4. Loving our Neighbors



### 1. Uses for Water - 5 minutes

Working with your team, list some of the ways in which you use water, or activities you do for which water is needed. (We will come back to this later in the lesson.)

---

---

---

---

---

---

---



## 2. Water in the Bible - 20 minutes

In your teams, read the following Bible verses together.



### **Ecclesiastes 1:7**

All streams run to the sea, but the sea is not full; to the place where the streams flow, there they continue to flow.



### **Isaiah 43:19-21**

See, I am doing a new thing! Now it springs up; do you not perceive it? I am making a way in the desert and streams in the wasteland. The wild animals honor me, the jackals and the owls, because I provide water in the desert and streams in the wasteland, to give drink to my people, my chosen, the people I formed for myself that they may proclaim my praise.



### **Isaiah 55:10-11**

For as the rain and the snow come down from heaven, and do not return there until they have watered the earth, making it bring forth and sprout, giving seed to the sower and bread to the eater, so shall my word be that goes out from my mouth; it shall not return to me empty, but it shall accomplish that which I purpose, and succeed in the thing for which I sent it.



### **Zechariah 10:1**

Ask the LORD for rain in the springtime; it is the LORD who makes the storm clouds. He gives showers of rain to men, and plants of the field to everyone.



### **Jeremiah 14:22**

Do any of the worthless idols of the nations bring rain? Do the skies themselves send down showers? No, it is you, O LORD our God. Therefore our hope is in you, for you are the one who does all this.

**Matthew 5:44-45**

But I tell you: Love your enemies and pray for those who persecute you, that you may be sons of your Father in heaven. He causes his sun to rise on the evil and the good, and sends rain on the righteous and the unrighteous.

**John 4:13-14**

Jesus answered, "Everyone who drinks this water will be thirsty again, but whoever drinks the water I give him will never thirst. Indeed, the water I give him will become in him a spring of water welling up to eternal life."

**Connections** - Now take a few minutes to consider together how these Bible verses might relate to the water uses or activities that you listed at the beginning of this lesson.

For example, because streams run to the sea (Ecclesiastes 1:7), we are able to use them for transportation.

Be prepared to share a few of the relationships you saw with the rest of the class.

---

---

---

---

---

---

---

---

---

---

**3. God's Gift - 10 minutes**

Without water, there can be no life.

As we review the water cycle, follow along with the drawing below. Each numbered arrow on the drawing corresponds to one of the terms listed below. Match each term with the corresponding arrow number.

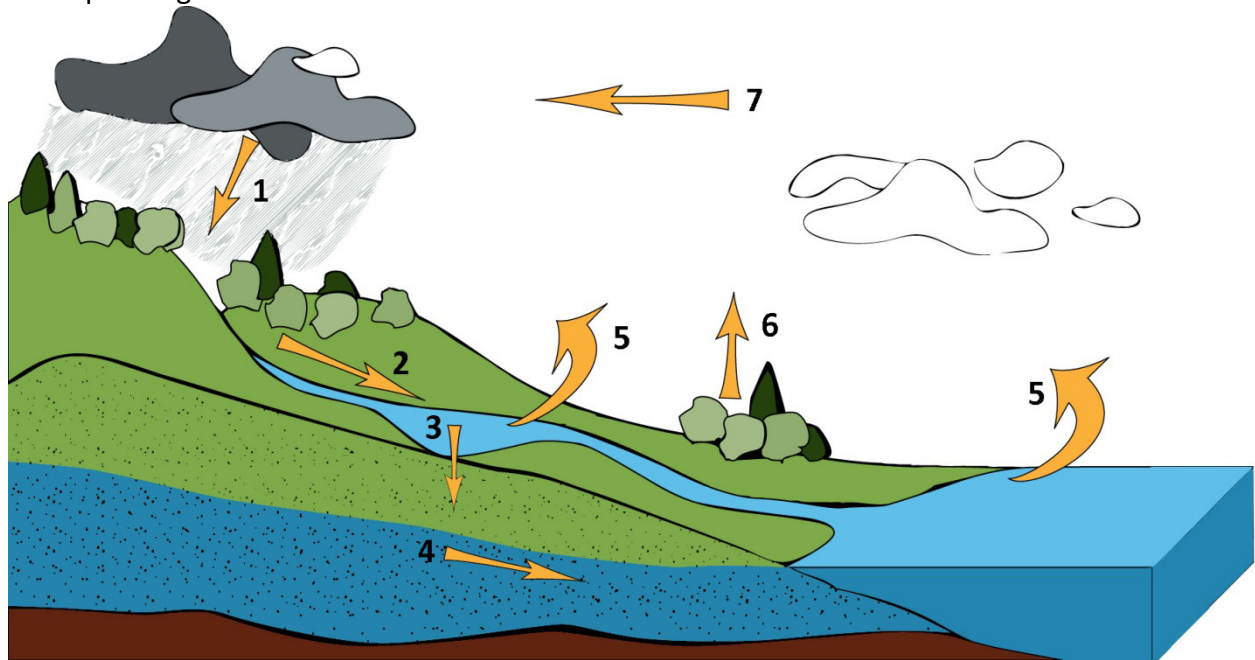

**Figure 2 The Water Cycle**

- \_\_\_\_\_ Precipitation (rain or snow)
- \_\_\_\_\_ Runoff
- \_\_\_\_\_ Infiltration
- \_\_\_\_\_ Groundwater

- \_\_\_\_\_ Evaporation
- \_\_\_\_\_ Transpiration
- \_\_\_\_\_ Clouds

**4. Loving Our Neighbors - 25 minutes**

**➤ Where does water come from?**

When you are finished labeling the water cycle phases, circle all of the locations on the drawing where you directly receive from God the water that you need for the uses or activities that you listed at the start of this lesson.



➤ **Where does water go?**

For a water use or activity that you listed, briefly share with the class where you think the water goes after you have finished with it.

➤ **Who is downstream from you? Who is upstream from you?**

Read the following Scriptures:



**Galatians 5:13-14**

You, my brothers, were called to be free. But do not use your freedom to indulge the sinful nature; rather, serve one another in love. The entire law is summed up in a single command: "Love your neighbor as yourself."



**Ezekiel 34:18-19**

Is it not enough for you to feed on the good pasture? Must you also trample the rest of your pasture with your feet? Is it not enough for you to drink clear water? Must you also muddy the rest with your feet? Must my flock feed on what you have trampled and drink what you have muddied with your feet?



**Philippians 2:3-4**

Do nothing out of selfish ambition or vain conceit, but in humility consider others better than yourselves. Each of you should look not only to your own interests, but also to the interests of others.

➤ **How then should we live?**

In what ways do you think these passages relate to the ways in which we handle the water that we use?

---

---

---

---

---





## Lesson 2.1 Proper Well Construction



### Purpose

*To become competent with the features of a properly constructed well, to better understand the hand pump system.*



### Objectives

*By the end of this lesson, participants will have*

- Examined the elements of a properly constructed well and
- Identified hand pump malfunctions resulting from improper well construction.



### Materials

- Poster of Well
- Markers and Flipchart



### Preparation

- Study lesson ahead of time.



### Time

60 minutes



### Steps

1. Introduction
2. Typical Well and Hand Pump
3. A Story
4. Activity



### 1. Introduction - 5 minutes

It takes more than a hole in the ground to make a good well\*. The manner in which a well is constructed can often limit the success of a hand pump. A properly located and constructed well can provide safe water for many decades. But a poorly constructed well can cause the down-hole components of a hand pump to fail prematurely.

A repair technician may be called to fix a pump and find that they are being called back over and over again to repair the same quickly worn-out parts. Other times the condition of the well may make a repair impossible. The repair technician must be able to recognize when the pump needs to be fixed and when the well needs to be fixed.

**\*Note:** Throughout this manual, the term “well” refers to a drilled well or borehole (a “tube well” in some countries). When the manual refers to a larger diameter well that has been dug by hand then the term “hand-dug well” is used.

**2. Typical Well and Hand Pump - 30 minutes**

As we go over each component of a properly constructed well, please write in the labels on the diagram below. Try to picture how the parts function together to make the system work as a whole. Keep in mind that different countries use different terms.

Label these parts: handle, head, spout, base, pad, borehole, sanitary seal, casing, gravel pack, well screen, riser main, pump rod, pump cylinder, tail pipe, aquifer, static water level.

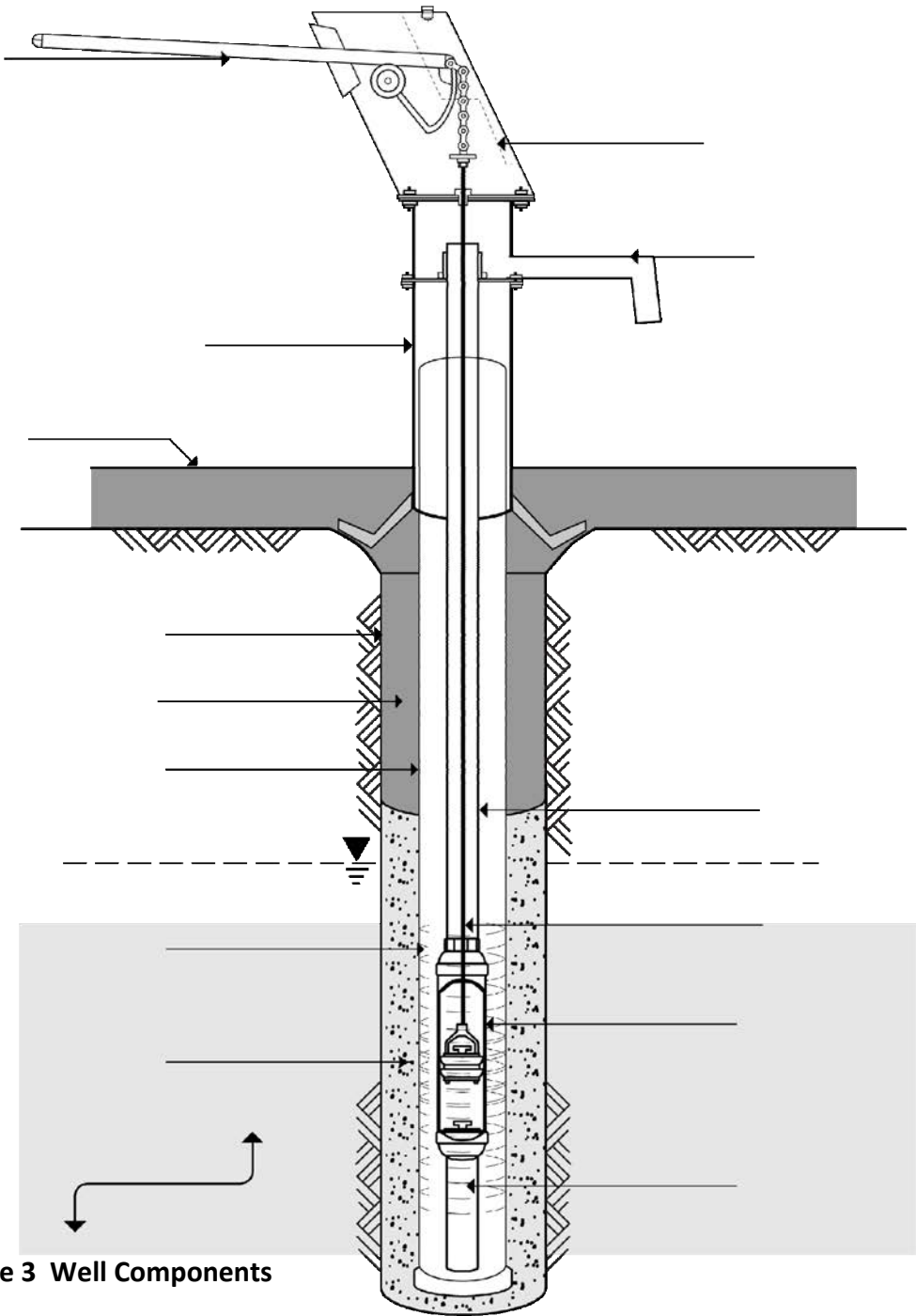

**Figure 3 Well Components**

## Key Elements of Well Construction

**Borehole** – The borehole needs to be about 50 mm (2 inches) wider all around than the diameter of the well casing. If you are using a 100 mm (4 inch) casing, to have 50 mm of space on all sides, the borehole would need to be 200 mm (8 inches) in diameter. If your casing is 75 mm (3 inches) in diameter then the borehole should be at least 180 mm (7 inches) in diameter. There can be no obstructions anywhere in the borehole. The borehole must be deep enough so that it extends below the lowest expected water level.

**Casing** – The wells we work with typically use PVC plastic pipe to line the borehole. The bottom is capped and the lower section is slotted to permit water to pass inside the casing. This slotted section of casing is often called the well screen. It is very important that the casing and well screen be strong because a casing with weak walls will collapse under the pressure caused by the soil and water. This collapse might not happen immediately, but perhaps months later if the water level drops.

Choose strong casing that won't collapse. The term used to describe PVC pipe strength rating is "Schedule" which refers to a set of universal standards. Thin-walled drain pipe, not suitable for use as well casing or screen, is rated Schedule 20 or lower. Heavier-walled pipe that is suitable for use in a well is rated Schedule 40. It might not always be possible to determine the strength rating of PVC pipe. A 100 mm (4-inch) diameter Schedule 40 PVC pipe will have a wall thickness of around 6 mm (0.25 inch). Using 75 mm (3-inch) diameter casing might save a little money, but Lifewater recommends 100 mm (4-inch) casing since that will allow a submersible pump to be installed in the well at a later date. Also, an Afridev pump requires a 4-inch casing.

**Gravel Pack** – Surrounding the well screen is a layer of small diameter, rounded gravel or coarse sand that has been sifted and washed. The gravel pack allows water to pass but prevents silt and fine sand in the soil around the borehole from entering the casing. (For this reason it is sometimes called a filter pack.) The grains need to be large enough so they can't get through the well screen. If the gravel pack is too thin, has gaps, or is not evenly distributed around the well screen, then fine particles will get into the casing. When this happens, the well may be said to be "pumping sand." The sand and silt gets into the pump causing premature wear and can eventually fill up the casing almost to the static water level.

After placing the gravel pack, the well must be "developed" to open up flow paths from the aquifer into the well screen. Drilling may cause clay to be smeared on the borehole walls and the bentonite clay and other materials used to thicken the drilling fluid can migrate a short way into the aquifer. "Developing" a well consists of vigorously pumping or bailing until a good flow of clear water is obtained. Without this step, which can take a day or longer, a well that could produce a good flow of water may only produce a trickle or none.

Choose gravel pack that works with your well screen. The individual grains should be no larger than 6 mm (1/4 inch) and no smaller than about 3 mm (1/8 inch) in diameter. It is best if the grains are all about the same size. They must be rounded, as found in river sand, not crushed as

would be found in a rock quarry. Round grains maintain open spaces between them, whereas angular grains lock together and do not allow water to easily flow between them.

**Aquifer** – This is a water-bearing layer that will yield water to a well. The rate at which an aquifer can produce water depends on how thick the layer is and how easily water can flow through it. Coarse sand and gravel makes a very good aquifer, fine sand and silt a very poor one, and clay usually prevents the movement of groundwater. A hand pump may be suitable for an aquifer with a low yield, but an electric submersible pump would not.

**Static water level (SWL)** – The level to which water rises in response to pressure in the aquifer. This is the depth to the water surface in the well measured when the well is not being pumped. The static water level (SWL) in many locations will be lower toward the end of the dry season and higher during and right after the rainy season. The borehole must be drilled deep enough below the seasonally lowest water level when the well is being pumped or else it will not have enough water in it. During an extended drought even a normally productive well could dry up if it is not deep enough. This is especially a problem with hand dug wells that have been fitted with a hand pump.

**Pump Pad and Sanitary Seal** – The parts of a pump installation that prevent surface water from contaminating the well. The sanitary seal is made of concrete that completely fills the space between the borehole and the casing. It should be at least 15 feet deep or to the water table if it is closer. The pump pad needs to be thick enough and reinforced to keep it from cracking and allowing surface water to seep into the well.



### 3. A Story - 10 minutes



**Figure 4 Forcing Casing**

A Lifewater trainer had just arrived at a drill site to give a partner crew advanced training. After introductions, the crew went back to work on the borehole they had started earlier in the day. The trainer watched the crew work for several hours and was impressed with their drilling skills.

They had been drilling through several different layers of clay and when the crew started installing the casing, a problem arose. They were having difficulty getting the casing into the borehole. They had just finished reaming it to 8 inches and were installing 4-inch PVC casing. It was a 20-meter deep borehole, but they could not get the casing past about 6 meters.

So they all grabbed onto the casing and started pulling it down as hard as they could. After one crew member climbed the drill mast to fill the casing with water to make it heavier the trainer yelled, “Stop!”

➤ Why do you think the trainer yelled “Stop!”?

---

The trainer explained that if the casing didn’t go easily into the borehole, then they would never be able to get a gravel pack around the well screen. The crew chief said, “This is how we always put in casing.” So the trainer asked, “Tell me about the last well you installed this way; does it produce clear water?” “No,” answered the crew chief, “it is always muddy.” So the trainer took that opportunity to remind the crew what the gravel pack does and how critical it is for the proper functioning of a well. After reaming the troublesome section several more times, the layer of swelling clay was conquered and the casing was installed with enough clearance to put in the rounded coarse sand needed to form a good gravel pack.

There are several lessons that can be learned from this incident, but the one we want to look at now is how things that the well drillers do – or don’t do – affect the long-term performance of the well and hand pump.



#### **4. Activity- 15 minutes**

Each team will be assigned one or more of the following problems related to well construction. For each problem, describe how it might affect the long-term performance of the hand pump. Discuss this for 10 minutes and then present your findings to the class.

Problem 1: Crooked borehole

Problem 2: No sanitary seal

Problem 3: Gaps in the gravel pack

Problem 4: Well not deep enough

Problem 5: Casing forced past a clay layer

Problem 6: Cracked pump pad







## Lesson 2.2 Operational Principles of Hand Pumps



### Purpose

To introduce the fundamentals of hand pump cylinder operation, including common wear points, and to standardize the names of cylinder parts.



### Objectives

By the end of this lesson, participants will have

- Developed a working vocabulary for pump repair;
- Understood the function of each part of a hand pump; and
- Considered ways in which a pump cylinder may fail.



### Materials

- Buckets of Water
- Clear plastic Mark II cylinder for demo (if available)
- One functional Mark II cylinder for each team
- Cylinder Parts Poster and Markers
- Cylinder Operation Poster



### Preparation

- Fill buckets with water
- Ensure cylinders are assembled and work properly



### Time

60 minutes



### Steps

1. Sylvia's Pump
2. Cylinder Operation
3. Identify the Parts
4. Experiment with the Cylinders
5. Identify Failure Points



### 1. Sylvia's Pump - 10 minutes

Please listen to this story.

This is Sylvia. She lives in a rural village with her parents, grandmother, and baby brother. One of her duties at home is to go to the village pump in the morning and evening to fill her buckets with water. It takes her 45 minutes each way. She has to miss school because it takes so long. She is even more worried about her baby brother. He gets sick whenever he has to drink the river water and once he nearly died from it.

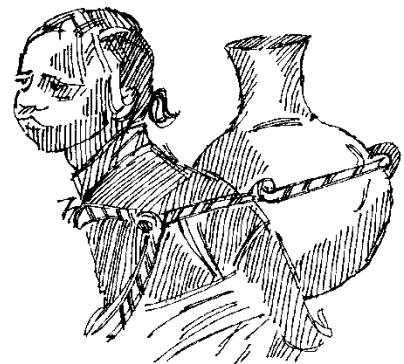

One morning, she goes out to the pump as usual, but when she moves the handle she just hears a strange sound. No water comes out. She knows that the pump is broken, and that means she must walk to the river to get water again. Sylvia wishes she knew how to fix the pump herself. But now she has to wait a long time for the pump repair technician to pass through her village again.

This is Sylvia's hand pump. It has a handle that moves up and down and it has a spout where the water comes out. What Sylvia can't see are the parts that are underground. These un-seen parts are the Riser Main with the Pump Rod inside, and the Pump Cylinder. In this lesson we are going to look at the parts of the main pumping mechanism, the hand pump's cylinder.

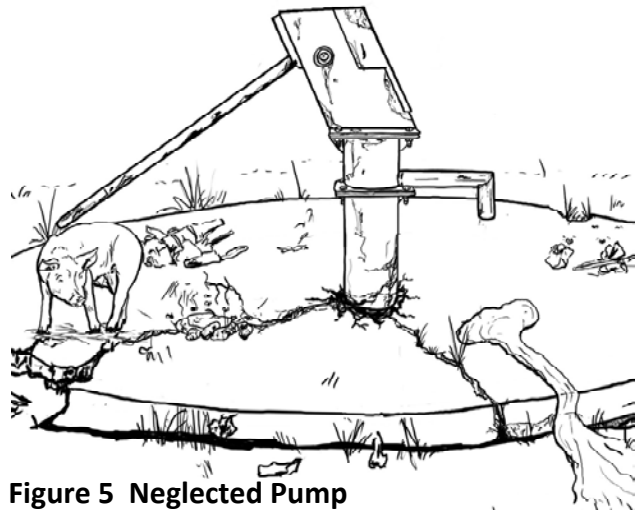

**Figure 5 Neglected Pump**

 **2. Cylinder Operation - 10 minutes**

Observe the facilitator using a hand pump cylinder. Study the drawings below to see how a cylinder functions.

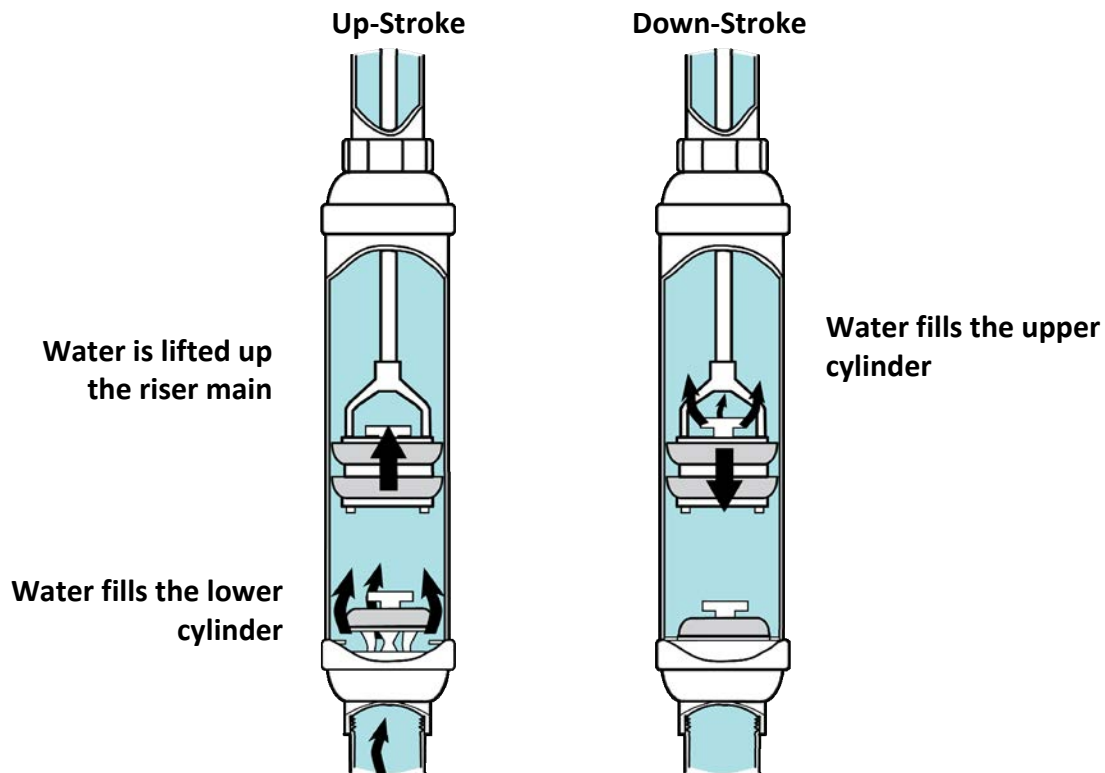

**Figure 6 Pump Cylinder Operation**



### 3. Identify the Parts - 10 minutes

Draw a line connecting the name to the component. Quiz your partner on the names of the cylinder parts.

Riser Main Pipe

Pump (Connecting) Rod

Upper Cap

Cylinder Barrel

Piston (Plunger) Assembly

Piston Valve (Traveling Valve)

Piston Seals

Foot Valve

Lower Cap

Tail Pipe

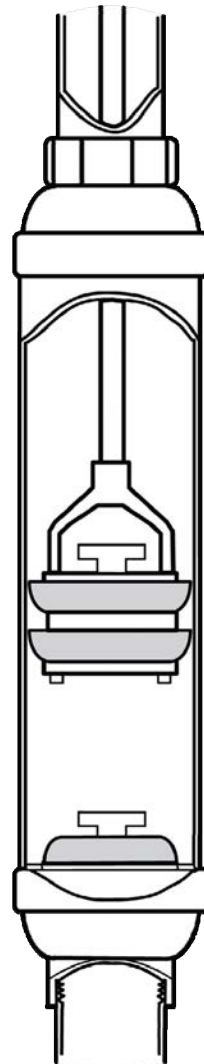

Figure 7 Cylinder Parts



### 4. Experiment with the Cylinders - 20 minutes

Get into groups of two or three and each of you take apart your pump cylinder by unscrewing the end caps and removing the plunger. Locate and identify each part. Experiment with it to see how it works. After you put it back together, try pumping water from the bucket.

**5. Identify Failure Points** - 10 minutes

With heavy use, even good pumps can break as often as every six months. Considering what you have just learned about the parts of a pump cylinder, let's try to identify what might have gone wrong with Sylvia's pump.

Which parts of a cylinder do you think are most likely to require repair or replacement? Why and how do you think that part is likely to fail?

Using the spaces below, write a brief description of all the possible cylinder failures you can think of and then draw a line to the affected cylinder part:

---

---

---

---

---

---

---

---

---

---

---

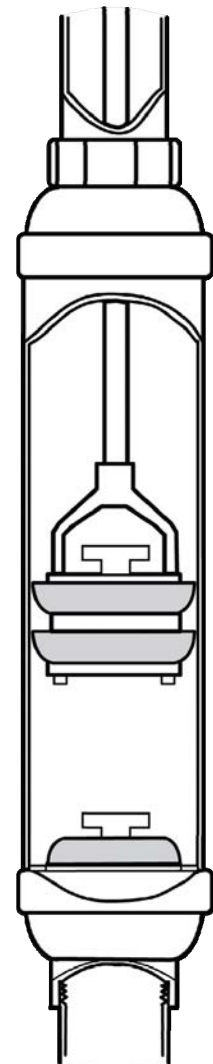
**Figure 8 Cylinder Failure**



## Lesson 2.3 Common Pump Types



### Purpose

To identify the different families of hand pumps and introduce the principles of VLOM, Preventative Maintenance, and Standardization.



### Objectives

By the end of this lesson, participants will have

- Classified pump types and identified the principle differences between them;
- Examined diagrams of common pump models; and
- Discussed the concepts of VLOM, Preventative Maintenance, and Standardization.



### Materials

- Posters of pump types
- Flipchart and markers



### Preparation

- Study lesson ahead of time.



### Time

60 minutes



### Steps

1. Hand Pump Families
2. Introduction to VLOM Pumps
3. Preventive Maintenance
4. Standardization



### 1. Hand Pump Families - 20 minutes

“Public Domain” hand pumps can be categorized into three main families, or types: **Suction**, **Direct Action**, and **Deep Well** pumps.

The following summaries are just a sampling of the most common designs of pumps that can be manufactured and sold by anyone. There are many other proprietary models licensed only to one company. Some of these are similar to the ones described here and others are quite different. Whenever an unfamiliar pump is found, do not attempt to work on it without a specific maintenance manual.

Refer to Appendix 7 for a chart of recommended operation depths for different models of hand pump.

## Suction Pumps

Suction pumps are the most simple. These pumps consist of an above-ground “cylinder” in which water is literally sucked up by the motion of the piston seals into the pump head and out the spout.

### Construction and Maintenance

Suction pumps are typically made of cast metal and most of the parts last a long time. The parts that wear out are easily accessible for replacement.

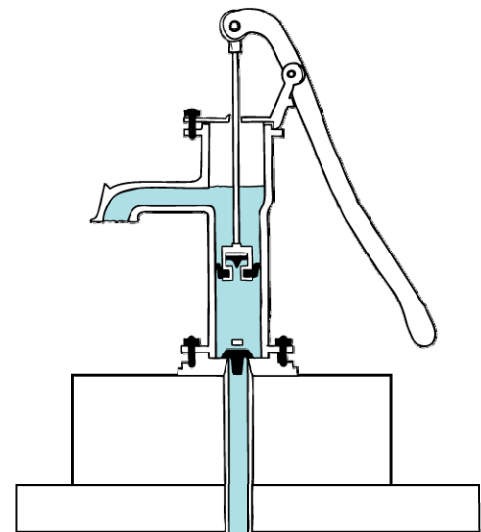

Figure 9 Suction Pump

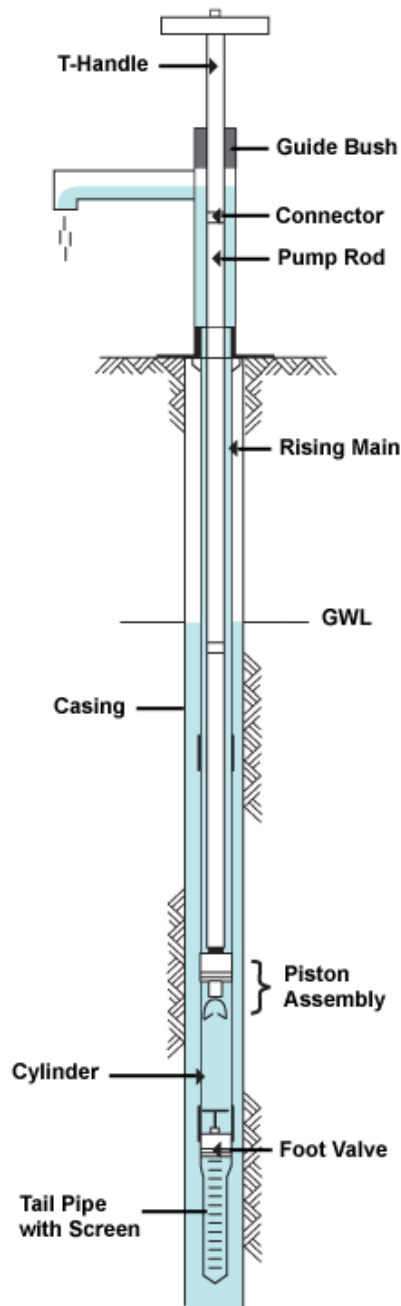

Figure 10 Direct Action Pump

Suction pumps have a maximum lift of 7-8 meters.

➤ What do you think limits this lift?

## Direct Action Pumps

Direct Action pumps have a below-ground cylinder and are usually operated by a ‘T’-bar handle. Some Direct Action pumps bring water to the surface on the up-stroke AND the down-stroke! The major pumping action takes place when the T is pushed down. When this happens, the extension of the T-bar, an empty and capped PVC pipe, is pushed into the water in the riser main. The volume of this PVC pipe displaces water, and because the foot valve is closed, the water is “pushed” up the riser main. When the T-bar is released, the buoyancy of the empty PVC helps lift the T-bar back up.

The Direct Action pump has a maximum lift of 15–25 meters.

➤ What do you think limits this lift?

### Construction and Maintenance

Direct Action pumps are typically made of PVC or polyethylene. Some designs can be built from off-the-shelf PVC components with a minimum of fabrication. With such simple construction, these pumps are usually easy to repair.

## Deep Well Pumps

Deep Well pumps have a cylinder that works like a suction pump, but the cylinder is placed below-ground beneath the water table. They are equipped with a handle that provides mechanical assistance to lift the water. The Deep Well pump has a metal pump rod, of various designs, attached to the piston which houses the traveling valve.

With special adaptations, some Deep Well pumps can lift water from as deep as 80 meters below ground.

- What is limiting the lifting height?

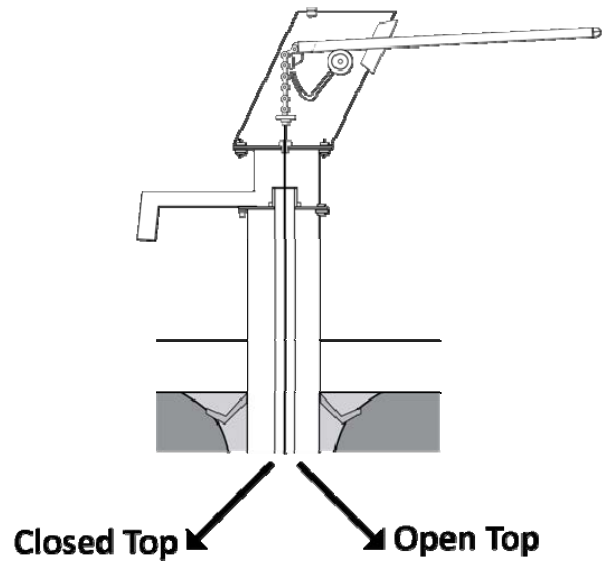

### Construction and Maintenance

Deep Well pumps come in a variety of designs. Some may only be manufactured by one company, while others are “public domain” and are made by many companies. The India Mark II, Mark III, and Afridev pumps are common public domain pumps. Most Deep Well pumps have cast or machined steel parts. This heavy-duty construction is necessary because of the wear caused by constantly lifting heavy columns of water.

The most important difference between types of Deep Well pump is how the pump piston and foot valve are serviced. On “closed-top” pumps, which were developed first, the entire riser main and cylinder must be removed. With an “open-top” pump, the cylinder is the same diameter as the riser main so only the pump rods need to be pulled out to service the piston and foot valve.

Open-top pumps were designed for Village Level Operation and Maintenance, or VLOM.

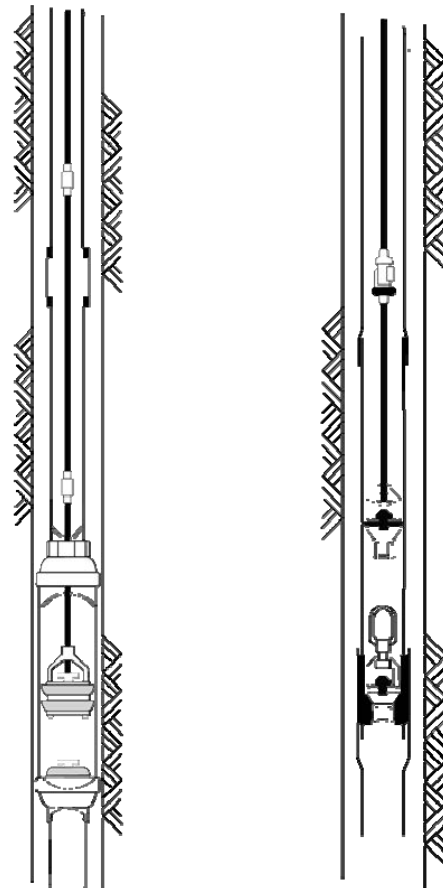

**Figure 11 Deep Well Pumps**



## 2. Introduction to VLOM Pumps - 10 minutes



**VLOM** stands for Village Level Operation and Maintenance, and is used to describe a hand pump that:

- can be operated by a small child;
- can be installed and repaired by a team of two or three persons;
- is durable against corrosive groundwater; and
- can have its quickly worn parts easily purchased and replaced.

Why are VLOM pumps needed? Many hand pump projects have failed because of:

1. The absence of a sustainable system of hand pump maintenance and repair;
2. The installation of pumps which were not suitable for the heavy usage they received;
3. The use of pump components which were damaged by corrosive groundwater; and
4. A lack of community involvement in important aspects of the project planning.

The careful choice of a VLOM hand pump can help solve the first three of these problems, but unless the community is involved from the beginning in all elements of the water project – planning, design, construction, and maintenance – it is unlikely that the hand pump will be sustainable.



## 3. Preventive Maintenance - 10 minutes

**Preventive Maintenance:** Preventative maintenance, as opposed to corrective maintenance, is the routine work done on a pump and its surrounding area to ensure that major breakages or contaminations do not occur. The capacity of the village to do routine maintenance on their pump will often determine the success of water projects for that village. When training village maintenance crews, it is wise to include a schedule of preventive maintenance tasks such as the following:

### Weekly:

- Lubricate moving parts.
- Check and tighten nuts and bolts.
- Make sure the pump is firmly set in the base.
- Keep well pad and area around the well clean and neat.

### Monthly:

- Check pump flow (discharge) rate and record results.
- Repair concrete base and apron as needed.



 **4. Standardization - 20 minutes**

Read the definition and case study below and share your thoughts on the advantages and disadvantages of hand pump standardization.

 **Standardization:** The term “standardization” refers to the government deciding to limit hand pump choices to a few models.

In the 1970s and 1980s many African governments were encouraged to use a limited number of hand pump types. The idea was that if only a few hand pump types were used in the country, then it would be easier for hand pump repair technicians and suppliers would not need to stock many different kinds of spare parts. They hoped that this “standardization” would stimulate self-sufficiency and eventually create a stable market for spare parts and tools.

However, the results of standardization have not always turned out as hoped. Below is an example of one such case.

 **Case Study:**  
 The Government of Uganda chose to standardize on the Uganda versions of the India Mark II and Mark III pumps (known as the U2 and U3). These pumps are manufactured locally and adapted to suit local groundwater conditions and community needs. However, there are over 1,000 existing Consallen hand pumps in the east of the country. They were installed for about ten years before the government decided to standardize. The Consallen hand pumps currently demonstrate higher levels of reliability than the U2/U3, but despite proof of the ability to manufacture these pumps locally, the Consallen was not selected as a standard pump for Uganda. In this instance it can be argued that standardization has done little to improve sustainability.

- Small group discussion: In ways might standardization be an advantage to maintaining a rural water supply and how it might be a disadvantage?

**Advantages of Standardization**

---



---



---



---



---

**Disadvantages of Standardization**

---



---



---



---



---

- Small group discussion continued: If standardization were applied on a regional basis, rather than country-wide, how might that change the advantages or disadvantages of standardization that you listed?

---

---

---

---

---

- Additional small group discussion (if time permits): Suppose you have been appointed as head of the Ministry of Water in your country. Would you implement hand pump standardization or take some other approach?

---

---

---

---

---



## Lesson 3.1 Tool Skills and Safety



### Purpose

To introduce the tools used in hand pump repair and explain their uses and the safety concerns associated with them.



### Objectives

By the end of this lesson, participants will have

- Been introduced to the principal tools used in pump repair; and
- Studied the uses and safety concerns associated with these tools.



### Materials

- Two lengths of threaded pipe and a coupling for each team
- Tools (see list in Appendix)



### Preparation

- Ensure each toolbox contains the proper tools
- Set up two lengths of pipe and a coupling to demonstrate the use of pipe wrenches



### Time

60 minutes



### Steps

1. Tool Rules
2. Toolbox Inventory
3. Practice the Right-Hand Rule



### 1. Tool Rules - 10 minutes

These are some rules that are suggested so that tools designated for pump repair are always available for pump repair. Pump repair can save lives by providing safe water. So if a needed tool is not available because somebody borrowed it to fix their motorbike, people are likely to suffer.







1. The tools that you are using are not your personal property. They are the property of the organization for which you are working so treat them with care and respect. Always keep them clean and in good working condition.
2. Never loan the tools, especially for purposes not related to pump repair. If someone in authority asks to borrow a pump repair tool, you might not be able to refuse them. In that case, go with the tools. You can help with the task and you can guarantee that you get all of the tools back.
3. Always know where your tools are. Maintain an inventory of the tools and check it often. Keep them in a safe place on and off the job site. While working, place tools on a tarp, tin sheet, or other clean surface.







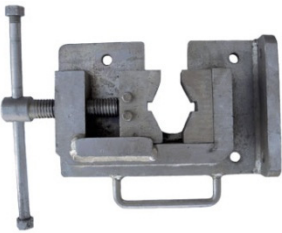

 **2. Toolbox Inventory - 30 minutes**





In your teams, go through your toolbox together. Find the tools described below and read the “Uses and Safety Notes” for each tool. Those who have experience with a tool should explain to the others how it is used.

Make a list of every tool in your toolbox. When you get access to a typewriter or a computer, make a formal Tool Inventory sheet that you can use to keep track of your pump repair tools. (If you need help with the names of tools not listed above, see the “Master List of Pump Repair Tools” in the Appendix.)

**Figure 12 Common Pump Repair Tools**

Tool Name	Picture	Uses and Safety Notes
Hard Hat		The most important tool you can use. A head injury can ruin your life. It is easy to get hit in the head while doing pump repair, so ALWAYS WEAR A HARD HAT!
Gloves		Most activities in pump repair are much safer wearing gloves. Many of the tools are sharp. Also, the riser main can have very sharp burrs (from improper pipe wrench use) that can cut even tough skin. (Remove your glove when fitting a nut to a bolt or you might drop the nut down the well.)
Afridev Tool		Primary tool used for working on the Afridev pump. The socket fits all bolts and the handle is used to lift first section of pump rod.
Afridev Retriever		When attached to the pump rod, this tool is used to retrieve the foot valve on the shallow style of Afridev pump.
Pipe Clamp		In the Mark II tool kit. (Several different designs are available.) Secures the riser main between lifts while the pipe is being joined or broken (disconnected). The clamp can hold a lot of weight so if it slips, move back! It is better to drop the pump than lose a finger. Can be set on edge and bolted to pump base to serve as a pipe vise for threading.
Rod Clamp		In the Mark II tool kit. Secures the pump rod while joining or breaking the riser main. If the rod is not always secured, the pump could fall to the bottom of the well. Also holds rod for threading.

Tool Name	Picture	Uses and Safety Notes
T-Handle		In the Mark II tool kit. Securely thread onto top of pump rod so if the rod clamp slips the handle will stop on the well casing. Also useful for lifting pump rod.
C-Wrench		Three included in the Mark II tool kit. Used to lift the riser main. Requires careful coordination between two or three people. Not recommended for lifts more than 30 meters. For deeper pumps use a tripod with block and tackle.
Tripod		Head is made with welded couplings to which legs made of 3-meter riser pipe are attached. Block and tackle attaches to head for lifting heavy riser main and pump. Be very careful to pull rope down, not away from tripod, or it may tip over.
Block and Tackle		Two sets of pulleys that, when joined together, are able to lift very heavy weights. Keep rope from getting tangled and make sure that the riser pipe is firmly attached before releasing the pipe clamp.
Pipe Elevator		Used for lifting riser main. Many different designs are available. Make sure it has a firm grip before releasing the pipe clamp.
Pipe Wrench		Joining and disconnecting threaded pipe and fittings. Normally use two wrenches together. Can pinch fingers, so wear gloves.
Adjustable Wrench (Spanner or Crescent wrench)		For tightening and loosening nuts and bolts. Normally use two wrenches together. If not adjusted properly, will slip off and damage the nut. Fixed-size "combination wrenches" do not have this problem.
Vise Grips		Also called locking pliers. Useful as a "third hand" to hold a bolt when tightening the nut. Also useful for gripping the pump rod before a more secure rod clamp can be applied. Can pop open, so must be held if used to clamp pump rod for very long.
Pipe Cutter		Used for making a clean cut in pipe. Tighten the wheel a small amount each turn. Use a reaming device or file to remove the burr from inside the pipe after cutting.

Tool Name	Picture	Uses and Safety Notes
Pipe Threader		Also called pipe threading die and handle. Cuts thread in riser main pipe. Use cutting oil and go slowly or the cutting teeth can break.
Pipe Vise		Holds pipe or rod securely when cutting or threading. Must be mounted on a firm base.
Hack Saw		Use for cutting pump rod or riser main. Also works well on PVC plastic, but not wood. Watch where you place your free hand because the blade can slip and cut you; wear gloves! Cut on the forward stroke and reduce pressure on the return stroke.
Rod Threader		Also called rod or bolt threading die and handle. Cuts threads in pump rod when the pump stroke length needs to be adjusted. Use cutting oil for smooth operation.

 **4. Practice the Right-Hand Rule - 20 minutes**

“What direction do I turn it?” is the question we ask every time we want to tighten or loosen a nut or bolt or pipe coupling. The “Right-Hand Rule” is an easy way to remember. Point your right thumb in the direction you want the object to move (tighten or loosen); the direction in which your fingers curl is the way it needs to be turned.

The pipe wrench is one of the most frequently used tools in pump repair. Although it is a simple tool, it can be difficult to master. You will be provided a section of pipe joined to a coupling. Take turns using the pipe wrenches to disconnect and reconnect them until you are comfortable using pipe wrenches.

When using two pipe wrenches, pull them toward each other, rather than pushing away. Use the ridges on a coupling to get a better grip. Keep the wrenches close to each other, leaving enough room for your hands. Fingers can get smashed if a tight fitting releases suddenly, so be careful where you put your hands.

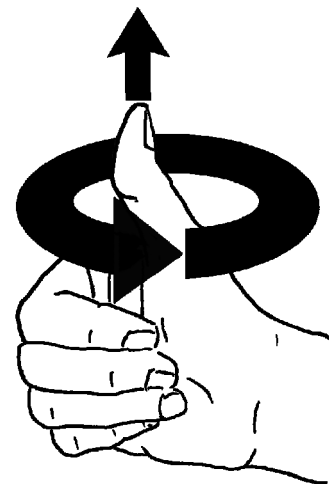

**Figure 13 Right-Hand Rule**

***Note:** This “thumbs up” gesture has a positive meaning in North America and Europe, but it is considered insulting in some countries. So be sensitive to the local culture when teaching the Right-Hand Rule.*



## Lesson 3.2 The Four Laws of Pump Repair



### Purpose

To introduce a good procedure for starting a pump repair session.



### Objectives

By the end of this lesson, participants will have

- Memorized the four most important things to know when approaching a pump repair situation.



### Materials

- None



### Preparation

- Study lesson ahead of time.



### Time

45 minutes



### Steps

1. Four Questions to Ask
2. Song Writing



### 1. Four Questions To Ask - 20 minutes

#### 1. Do you have PERMISSION to work on this pump?

Before beginning, it is very important to include the community in the repair of the pump. The Water Committee, or other responsible persons, should be gathered to discuss the problems and offer suggestions about how they want to contribute to fixing the pump.



#### Case Study #1

In Kenya, a pump that appeared to be broken was repaired by a group of Americans without first asking permission. It was easy; they just had to reconnect the pump rod to the chain on the India Mark II. They later learned that the community had intentionally disconnected the chain because the well was contaminated and they did not want people to drink from it.



#### Case Study #2

A pump repair team found a broken pump while they were visiting a village in Liberia. It needed some welding so they took the pump out of the ground, put it in their truck and drove back to their shop in town to make repairs. Soon the police showed up to arrest them because the villagers accused them of stealing the pump! After that, it took a lot of explaining to get the people to trust them to make repairs.



### Case Study #3

In Zambia, the pump repair team thought first to ask the chief for permission to fix the well in his village. He granted permission and was so happy with the fixed pump that he donated a piece of land for a new church to be built. If they had not asked, they would have missed the blessing and likely offended the chief, instead of making a good friend.

## 2. Is there WATER in the well?

The pump may appear broken simply because the well is dry. Use a water level indicator, flashlight, or mirror to be sure there is enough water to pump. Ask the people, “Is water ever pumped from this well? What time of year?” Sometimes water levels are seasonal, especially in shallow boreholes.

## 3. Do you know HOW to work on the pump?

If not, then ask yourself, “Should I really start on this?” It is not enough to justify experimenting by saying, “If I fail then they are not really any worse off.” A bad repair job will hurt your credibility. So choosing to “experiment” is not a decision to be made lightly. The more pump repair experience a technician has, the better his or her chances are of being able to repair an unfamiliar pump.

## 4. Do you have the TOOLS and the PARTS to fix the pump?

A poorly done job gives the pump repair team a bad reputation. It may spoil anything else you say or do, including your Christian witness. Again, experience should guide the decision whether to attempt a repair on an unfamiliar pump.



## 2. Song Writing - 25 minutes

Gather with your team and **compose** a short song that incorporates each of the Four Laws of Pump Repair. You have 10 minutes to prepare it, and then we will present our songs to the class.





## Lesson 3.3 Hand Pump Repair Procedures



### Purpose

To introduce a systematic approach to repairing a hand pump.



### Objectives

By the end of this lesson, participants will have

- Considered the importance of using consistent pump repair procedures.



### Materials

- A set of the “Ten Steps” cards for each team (not in order)



### Preparation

- Study lesson ahead of time.



### Time

60 minutes



### Steps

1. Exercise
2. Ten Procedural Steps
3. Common Pump Problems



### 1. Exercise - 20 minutes

You will be given slips of paper with ten pump repair steps written on them. Discuss the steps among your team and arrange them in what you feel is the best sequence. Assume that this is your team’s first visit to this village to repair a pump. Lay the steps out on the floor so we can review them together.

There are different ways that we might have entered this village, such as being invited by the Water Committee, hired by the government, sent by the church, or just driving by and seeing a broken pump.

- How might the way in which we have entered the village to work on the pump affect the procedures that we follow?



### 2. Ten Procedural Steps - 30 minutes

Evaluating a pump repair problem requires a carefully considered approach. Ideally, a pump repair technician will think through the problem before taking the pump apart. The ten procedures or steps described in this lesson cover more than merely dealing with the mechanical problems of the pump. Because lack of community involvement is often the reason why the pump is not functioning in the first place, it is important to work closely with the people who are responsible for the pump.

This section summarizes key steps that should be taken to approach the assessment and repair of a hand pump. Take some time to thoughtfully read through the following text. Underline anything that stands out to you. Bring up any questions you have in the class.

### **1. Briefly look at the hand pump for obvious clues to its condition.**

If the pump can easily be seen as you enter the village, take a quick look at it. Do you recognize the pump, understand how it works, and have the necessary tools and parts to repair it?

Look for clues:

- Are there obvious problems, such as a missing handle, broken head, or signs that it has not been used for some time?
- Is the pump handle worn shiny indicating the pump is actively used?
- Is the pump base or pump head loose?
- Are weeds growing in the runoff channel and soak-away pit?
- Is there a worn path to the pump?
- Are there signs of iron staining on the pad?
- Is there lots of sand under the pump spout?
- Are there cracks in the pump pad, or signs of erosion around it?
- Is it apparent that the concrete pad has been previously repaired?
- Is the pump pad large enough?
- Does someone come to talk to you when they see you looking at the pump?

### **2. Talk to the villagers about their hand pump.**

Ask who is in charge of the hand pump; is there a Water Committee? Ask those who are responsible, “What is the story of this pump?” You want to learn:

- Is the well of high value to the village?
- Do the villagers have a sense of ownership of the well?
- Do the villagers like the water or do they object to its color, taste, or odor?
- Do they have cultural biases or myths which limit their use of the hand pump?
- Do they like the look and feel of the pump?
- Is the well in a good location?
- Who installed it and when was it installed?
- How deep is the well and how much water is in the well?
- How far down is the pump cylinder?
- When was the last time that the piston seals were changed?
- How long has the pump not worked?
- Is someone in the village trained to maintain or repair the pump?
- Are there spare parts in the village?

Some of this information can be learned from direct answers, but much of it may take time to draw out. Make an effort to listen; this is not a stage of the repair process that can or should be rushed.

The person in charge of the hand pump may have a Repair Record for the pump, or other information which may be useful. If they don't have one, fill one out for your record and offer a copy to the pump caretaker.

A very important subject to discuss with the Water Committee or other responsible party is the cost to repair the pump and who will pay for it. This is normally set by the policies of the organization for which you are working. In most cases the question of cost should have been decided before you arrive to repair the pump. Even so, it is important to review the details and write them out so that everyone understands. Some organizations have found it useful to have a written contract that defines what the repair will involve and how the costs will be paid.

By the conclusion of this discussion, ensure that you have permission to work on the pump. Also ensure that the village will assist with labor and materials as appropriate.

### 3. Test the hand pump.

Inspect the above ground components of the hand pump. Check to see if the handle bearings or connecting chains and bolts are broken or seized. Is the pump base securely fastened to the cement pad? Are all nuts & bolts in place and tight?

Try operating the hand pump. Use all of your senses. Does the handle move smoothly up and down without much sideways motion? Does the handle feel very heavy or very light to operate? Is there enough weight of water to pull chain down? Observe any water that comes out. Is it full of sediment?

Listen for unusual sounds; is water leaking from the riser main? What sounds does the pump or connecting rods make?

Conduct a pre-repair hand pump performance test as described below and record the results on the Repair Record.

#### Hand Pump Performance Testing Procedure\*

- Pump Test:**
1. Operate the pump until water comes out of the spout.
  2. Place a bucket under the spout and then pump 40 full strokes.
  3. Measure and record the volume pumped.

[Alternative: Count the number of strokes to produce 20 liters (5 gallons).]

- Leak Test:**
1. Let the pump be idle for five minutes.
  2. Count the number of strokes before water comes out again.

**Table 1 Pump Performance Ratings**

	<b>Pump Test</b>	<b>Leak Test</b>
<b>OK</b>	>10 liters	<5 strokes
<b>Poor</b>	<10 but >3 liters	>5 but <10 strokes
<b>Broken</b>	<3 liters	>10 strokes

\*Source: Kjellerup, Brent and Asimah, S.E. "Hand Pump Performance Monitoring" proc. 26<sup>th</sup> WEDC Conference, 2000.

#### **4. Ensure there is water in the well.**

Is the pump cylinder below the water level when the well is being pumped? Loosen the pump from the base or open a pump port and look down the well with a flashlight or reflected sunlight. Use a measuring tape or weighted string to determine the depth to the water table.

#### **5. Disassemble the hand pump.**

This is a potentially long task. Before you start, ensure that it is absolutely necessary to disassemble the pump. Do you know what is most likely wrong? If you do, discuss repair cost and timing with the villagers. If they are willing to proceed then disassemble the pump to confirm what you think is the problem.

Is it necessary to remove the rising main or is there an open top cylinder? If so, is the use of a tripod necessary? Keep track of your tools and the pump parts. Put bolts and nuts in a secure place. Move unused tools away from the pad so they don't become a trip hazard. Set up a perimeter rope to keep visitors at a safe distance from the work.

If lifting a Mark II or similar pump using C-wrenches, be sure to lift with your legs. Keep two things in mind at all times: safety and avoiding riser main disconnects. Keep a T-Handle securely attached to the top of the pump rods in case the riser main has become separated. Communicate each movement to the other team members.

Observe the riser pipes as you bring them up. Are they bent, worn or wet? When they start getting wet, this is either the water level or just below where there is a leak in your riser main. If it is the water level it should match the static water level you will measure after all of the pump is removed from the hole. Observe which riser main connections hold water and which ones don't. Watch for water leaking from holes in the riser main. As you remove the pipes, put them on boards to keep them off the ground.

After the pump has been removed, measure the well depth, diameter, and note the type of casing. Record this information in the Pump Repair Record. Also be sure to look down into the borehole (using a mirror to reflect the sun's light) to check for obstructions, broken casing, or sediment.

Finally, inspect the cylinder because it is often the source of the malfunction. What is the condition of the piston seals, the travelling valve, and the foot valve? Inspect the inside of the cylinder barrel; is it smooth and straight, or is it worn and uneven?

#### **6. Discuss the problem with the villagers and what the repair will cost.**

If you need time to obtain parts or the villagers need time to raise money, reassemble the pump. This will keep the parts from getting lost and keep debris from being dropped into the well. If the villagers do not want to pay for the repair, put the pump back together and leave them with your contact information and repair cost. If they do not want to take

care of it, only repair the pump if you are willing to be responsible for it from now on. (This approach may not apply with some organizations, depending on their strategy.)

### **7. Repair the hand pump.**

While you are working on the pump, train and equip at least two local villagers to do future repairs and ensure they know how to contact you (the Lifewater Partner) and where to get required parts. Here is a general guideline:

- Change the piston seals, even if they are not badly worn, and inspect the cylinder barrel liner for wear. Test the cylinder before reinstalling it in the well.
- Ensure that the piston clears the cylinder top and bottom during each stroke.
- Check handle weight... use counterweights or the extend handle if necessary.
- Make sure that all bolts are tight.
- Repair the cement pad as needed.
- If needed, discuss fencing off the hand pump area with the villagers.
- Examine the grade around the pump to see if it can be improved to force drainage away from pad.
- Clean out the soak pit as needed.
- Chlorinate the well (for hand-dug wells wipe components with bleach water).
- Take water quality samples (optional, but required in some countries).

### **8. Replace the pump in the borehole.**

Before putting the cylinder back in the well, whether it's new or used, test it, then test it again. Conduct an upstroke test in the bucket and then lift the cylinder out of the bucket and see if the cylinder holds water. If it does, push up the bottom check valve to ensure it is working properly. Add pipe dope or Teflon tape to the pipe joints. For each length of pipe, put a coupling on the top rising main pipe as a back-up.

When setting the pump intake level, don't be afraid to make the pump better! Consider the best pump depth relative to the static water level, to the borehole depth, the pump capacity, and fluctuations between the wet and dry season water levels. Use a tail pipe below the cylinder if there is sufficient space.

Any time a borehole is exposed the well must be chlorinated. (Not always practical with a large-volume hand-dug well. See the Well Disinfection lesson, pg 39.)

Conduct a post-repair hand pump performance test as described above and record the results on the Pump Repair Record. If the post-repair test does not show a significant improvement then ask, "Why? What did we overlook?" You will find yourself in a situation where you test the well and discover that there is still a problem. It will be late in the day and a long drive back. Decide now that you will not quit, saying "They are better off than they were." Whatever you do, do all to the Glory of God (1 Corinthians 10:31). Think of every well you work on as the well that Jesus drinks from; what you do for the "least of these" you are doing for Jesus (Matthew 25:40).

### 9. Reinforce community ownership of the pump.

Remember to pray with the community over the pump. Give thanks for being able to fix the pump.

The community will be very happy after seeing water coming out of their borehole after months or years of not working. This is a good time to discuss with leaders how to encourage the community to appreciate the value of their well as a resource that can help improve community health and well-being. Tell them what work you did. Emphasize their ownership of the well.

Review community plans for pump oversight and maintenance. Does everyone know how to minimize maintenance problems? Such as:

- Do not allow children to play on the pump.
- Use long full pump strokes, not short quick ones.
- Tell them who to contact if problems develop.

Make sure that everyone knows to wait 24 hours after chlorination to drink from the well. Do not allow the villagers to use the well during this time, so they don't get sick from the chlorine or decrease the chlorine contact time in the borehole. Use a chain and padlock to lock the pump handle to the pedestal if necessary, and give the key to the chief. After 24 hours, pump until you stop smelling chlorine (see the Well Disinfection lesson).

### 10. Learn from your experience.

Were you correct in your initial guess at what the problem was? If the real problem was different than what you suspected at the beginning, then what did you overlook? Discuss this with the team so the next time you come upon a pump with similar circumstances you can make a more accurate assessment.



### 3. Common Pump Problems - 10 minutes

The following are problems that a pump repair technician will often encounter. A pump may have several things wrong, which can make diagnosis difficult. Never be satisfied with fixing just one problem; carefully check to see if anything else might need repair.

<u>Problem</u>	<u>Underlying Cause</u>
Low yield (less than 10 liters in 40 strokes)	Worn piston seals or lowered water table.
Prematurely worn piston seals	Sand or silt in the well.
Needs many strokes to bring water up	Leaking foot valve or perforated riser main.
Frequently separated pump rod or chain	No lock nut or joints not adequately tightened.
Broken pump rod	Crooked threads or improperly tightened joint.
Contaminated water	Well is too close to a latrine, no sanitary seal, broken pad.



## Lesson 3.4 Well Disinfection



### Purpose

To learn how to properly calculate the amount of chlorine needed to effectively disinfect a well after working on the pump.



### Objectives

By the end of this lesson, participants will have

- Learned how to determine the proper amount of chlorine to use to disinfect a well.



### Materials

- Poster of Disinfection Table
- Bottle of locally-obtained chlorine bleach



### Preparation

- Review the calculations for yourself



### Time

60 minutes



### Steps

1. Why Disinfect?
2. How Much is Enough?
3. Practice



### 1. Why Disinfect? - 10 minutes

It is likely that the dirt around a pump pad contains ground-up feces which harbor dormant, disease-causing bacteria. These can remain alive for a long time and can cause diseases after they get into a well. For this reason, always place the pump rods, riser mains, and pump cylinder on blocks of wood so that they do not touch the ground. But even with this precaution, working on a hand pump can introduce contaminants into the well. So it is necessary to always disinfect a repaired well by adding chlorine to it.

### The three most important things to remember for well disinfection are:

1. The amount of chlorine required depends on the volume of water in the well and the concentration of the chlorine source. Water volume is calculated from well depth, static water level and borehole diameter (well casing plus gravel pack). The concentration recommended for “shock chlorination” is 250 milligrams per liter.
2. The chlorine should be mixed thoroughly in the well casing outside of the riser main, pumped until you smell chlorine in the outflow, and then left in the well casing and inside the pump overnight.
3. The chlorine **must** be completely pumped out before people drink from the well.

**2. How Much is Enough? - 25 minutes**

The question, “How much chlorine to use?” must be answered using some mathematics, but the calculations can be simplified. This lesson presents a table that provides a “disinfection Rate” for use with a borehole. (The formulas by which those numbers were calculated are described in Appendix 2.)

To determine how much chlorine to add to a well, it is necessary to know three things:

- Diameter of the well casing (see note below for hand-dug wells).
- Depth of water in meters (to convert feet to meters, divide feet by 3.28).
- Concentration of chlorine in your source (either 3.5%, 5% or 70%).

**Four easy steps:**

1. Determine the depth of water in the well. Measure the well depth and then subtract the distance from the surface to the static water level. [The Well Disinfection Table is based on meters, so to convert feet to meters, divide feet by 3.28.]
2. Find the row in the Well Disinfection Table that describes the source of chlorine that you have. Most liquid bleach sold in the market for cleaning or for washing clothes is 3.5% chlorine. The label on the bottle usually gives the concentration. Chlorine powder is normally 70% chlorine.
3. On the row in the table for your chlorine source (either row 1, 2, or 3), read to the right until you come to the column that represents the diameter of your casing. The number in that square is your “Disinfection Rate.” This is 0.08 when using 3.5% bleach in a 4-inch casing.
4. Multiply the appropriate “Disinfection Rate” by the meters of water in the well.

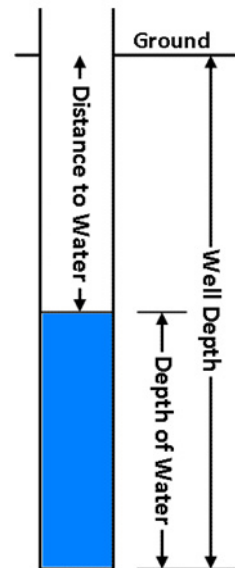

**Figure 14  
Well Depth**

**Table 2 Well Disinfection<sup>1</sup>**

Row	Disinfection Rate	Casing Diameter	75mm (3")	100 mm (4")	125 mm (5")	150 mm (6")
1	Liters of 3.5% liquid bleach per meter of water		0.05	0.08	0.11	0.16
2	Liters of 5% liquid bleach per meter of water		0.03	0.05	0.08	0.11
3	Tablespoons of 70% Powdered Chlorine <sup>2</sup> per meter		0.21	0.33	0.48	0.66
4	% Reduction if there is no gravel pack <sup>4</sup>		33%	25%	20%	16%



## Notes

1. The Well Disinfection Table is intended only for use with a borehole. A hand-dug well typically has a diameter of a meter or more. Even if there is only two meters of water in the well, it would take 11 liters of 3.5% bleach to disinfect it. And then it would require many hours of pumping to reduce the chlorine to a safe drinking level. After working on a pump in a hand-dug well, use a bleach solution (1 part bleach to 10 parts water) to wash the pump cylinder, pump rods, and riser main before putting them back into the well.
2. “Powdered Chlorine” is usually Calcium Hypochlorite. Some “swimming pool disinfectants” contain powdered chlorine but they also have chemicals for controlling algae that are unsafe for use in drinking water. Always read the label and be certain that what you are using is intended for treating drinking water. Using a scale to measure the amount of powder to add is the most accurate method, but a scale is not usually available, so grams of powder (row 4) have been converted to the volume of a standard tablespoon (row 3) as a more convenient measurement.
3. The Disinfection Rate is calculated assuming that the well has a good gravel pack about 50 mm (2”) thick. If it is known that there is no gravel pack, then row 4 of the Well Disinfection Table shows the percentage by which the amount of liquid bleach or powder may be reduced.



### 3. Practice - 25 minutes

Working together as a team, study the two well disinfection examples. Then use the Well Disinfection Table to solve the well disinfection problem on the next page. Write out your calculations.



**Well Disinfection Example #1:** A 100 mm diameter well casing is 30 meters deep and the distance from the surface to the water level is 15 meters. So there is 15 meters of water in the well. It is believed that the borehole was about 150 mm in diameter and a gravel pack was installed. A bottle of laundry bleach was found in a store and the label shows that it has 3.5% chlorine.

Find the row in the Well Disinfection Table that says, “Liters of 3.5% liquid bleach per meter of water” then read the number in the column labeled “100 mm” – that is 0.08. Then multiply 0.08 liters of bleach per meter by 15 meters of water to get 1.2 liters of bleach. Pour this amount into the well before re-installing the repaired pump, and then pump a little water just until you smell chlorine. Lock the well for 24 hours, and then pump until no more chlorine can be smelled. The well is now safe to use.

#### Calculations:

Water Depth: 30 meters - 15 meters = 15 meters

Chlorine Dose: From Table for 3.5% Bleach and 100 mm casing,

0.08 liters bleach /meter of water x 15 meters water = 1.2 liters of bleach

**Well Disinfection Problem:**

**Well casing diameter:** 125 mm

**Borehole diameter:** 175 mm (there is a gravel pack)

**Total well depth:** 34 meters

**Ground surface to water level:** 21 meters

**Chlorine source:** Laundry bleach believed to be 5%

➤ How much bleach should be added to disinfect the well? \_\_\_\_\_ Liters

Your calculations:

➤ If the well does not have a gravel pack, how much bleach should be added?  
(Hint: Read Note 4 below the Well Disinfection table.)

Your calculations:



**Well Disinfection Example #2:** A 75 mm diameter well casing is 18 meters deep and the distance from the surface to the water level is 12 meters. There is 6 meters of water in the well (18 m minus 12 m). It is believed that the well was installed without a gravel pack. The government water office provided a package of powdered chlorine. The label does not show the percentage chlorine, so we must assume it is 70%, since that's what is common for calcium hypochlorite.

Go to the row in the Well Disinfection Table that says, "Tablespoons of 70% Chlorine Powder per meter of water" then read the number in the column labeled "75 mm" – that is 0.21. Then multiply 0.21 tablespoons of powder per meter by 6 meters of water to get 1.26 tablespoons.

However, because the well in this example has no gravel pack, we need to reduce the amount of chlorine we add. Read row 6 of the Table ("% Reduction") to find 33% in the 75 mm column. Reduce the 1.26 tablespoons by 33% [ $1.26 - (1.26 \times .33)$ ] to get 0.8 tablespoon. So in this example you would dissolve a little less than a tablespoon of powder into several liters of water in a bucket and pour that into the well before reinstalling the repaired pump. Then pump a little water just until you smell chlorine. Lock the well for 24 hours, and then pump until no more chlorine can be smelled. The well is now safe to use.

**Calculations:**

Water Depth: 18 meters - 12 meters = 6 meters

Chlorine Dose: From Table for 70% Powder and 75 mm casing,

0.21 tablespoon/meter of water x 6 meters water = 1.26 tablespoons.



## Lesson 3.5 Planning and Mobilization



### Purpose

*To emphasize the importance of preparation before going out to repair a pump.*



### Objectives

*By the end of this lesson, participants will have*

- Discussed the consequences of an inadequately repaired hand pump and
- Considered how to be prepared to do a pump repair.



### Materials

- Flipchart and markers



### Preparation

- Study lesson ahead of time.



### Time

45 minutes



### Steps

1. Discuss a Pump Repair Case Study
2. Develop a Pump Repair Checklist



### 1. A Pump Repair Case Study - 20 minutes

*For a reminder on the role of a lock nut, refer to the “Introduction to India Mark II” lesson.*

- Have you ever heard the ancient proverb, “For lack of a nail”? It goes like this:



For lack of a nail the shoe was lost.  
For lack of a shoe the horse was lost.  
For lack of a horse the rider was lost.  
For lack of a rider the battle was lost.  
For lack of a battle the kingdom was lost.  
And all for the lack of a horseshoe nail.

- Is there a proverb or phrase in your country that teaches the same lesson?

### Listen to this story...

A repair team was asked to fix a hand pump that had been out of service for five months. During that time the community of 60 families had to walk 2 kilometers each way to get their water from a lake. The children were often sick with diarrhea from drinking the lake water.

When the repair team opened the pump, an India Mark II, the problem was obvious. The pump rod had become disconnected from the chain. When the pump caretaker saw it he said, “Ah! That is what happened the last time the pump broke.”

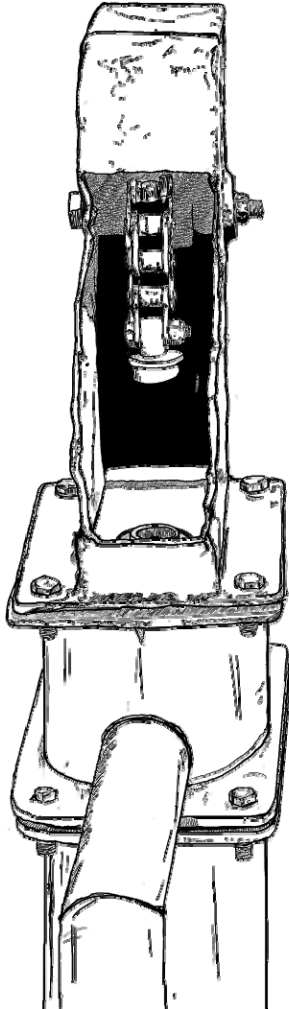

Figure 15 Broken Mark II

Before the pump repair team reconnected the chain they wondered, “Why did the pump rod come off – not just once, but twice?” Looking more closely at the top of the pump rod, they saw that there was no lock nut. Whoever previously worked on that pump had failed to secure the rod to the chain with a nut. The rod threads into the chain, so they must have assumed that was enough. But it certainly was not enough, as proved by the twice-disconnected rod.

We do not know for sure, but we can guess that the first pump repair person who failed to add a lock nut did not have an extra nut with him. It was a 45-minute drive into town on a bad road. So, rather than take the trouble to drive all that way to get a nut, he connected the rod to the chain and left.

But what was the result of not taking the trouble to drive 1-1/2 hours to get a nut? A community of 60 families had to suffer for five months without safe water. Children got sick from drinking unsafe water. Perhaps some even died; all because someone did not adequately prepare ahead of time or take the trouble to drive into town to get a nut.

➤ What can we learn from this story?

---

---

---

---

---



## 2. A Pump Repair Checklist - 25 minutes

To **mobilize** is “to prepare for action.” **Mobilization** is getting ready to do the job right.

- What is a word or phrase in your language that means “to prepare for action”?

Write it here: \_\_\_\_\_

- How can we best prepare to go out and repair a pump?

Make a list of the things that we should bring:

---

---

---

---

---

*All tools, tripod, buckets, rope, chlorine bleach, pump cylinder, piston seals, riser main, pump rod, bolts & nuts, cement, Repair Record & pen, GPS*



### Regarding Spare Parts

There is no simple solution to the problem of “supply and demand” for pump parts. Organizations doing hand pump repair have adopted different procedures and policies for handling spare parts. Some examples are:

- The village might already have spare parts on hand which the repair technician uses to fix the pump.
- The repair technician collects money from the villagers and then uses that to purchase parts at a store.
- The repair technician may carry a small supply of parts that he uses and then includes the cost of those parts in the total cost of repairing the pump.
- The organization for which the repair technician works maintains a pump repair warehouse and the technician fills out a request form to obtain parts. This usually requires two trips to the well; the first to determine what parts are needed and the second to fix the pump.

The policies of the organization for which you work will determine how you obtain spare parts. There needs to be a balance between efficiency (reducing the number of trips to fix the pump) and maintaining control over the supply of parts.





## Lesson 3.6 Pump Repair Record



### Purpose

*To instill a sense of the importance of good record-keeping and reporting.*



### Objectives

*By the end of this lesson, participants will have*

- Practiced completing a pump repair record.



### Materials

- Blank Hand Pump Repair record forms
- Poster of a completed Record



### Preparation

- Study lesson ahead of time.



### Time

60 minutes



### Steps

1. Why Keep a Record?
2. Hand Pump Repair Record Contents
3. Learn From Each Other
4. Summarize What We Have Learned



### 1. Why Keep a Record? - 10 minutes

When you repair a hand pump there usually are villagers watching. Their presence is very obvious – even annoying at times. But many other people, who may not be as obvious to you, are interested in that pump repair job:

- There is the Village Water Committee and other village leaders.
- There is your supervisor and, in a larger organization, other people to whom he or she reports, including the financial manager who keeps track of labor and other costs.
- There is the government agency responsible for rural water development.
- There may be donor organizations that contributed money for your tools, training, and pump repair work.
- There is another pump repair technician who will come to repair that pump again at some time in the future.

All of these people want to know about the work that you are doing on this pump. But, unlike the villagers, they are not able to watch so you need a way to tell them about the pump and what you did. This communication is the purpose of the Hand Pump Repair Record. Because so many people rely on it, you must take care to complete it accurately.



## 2. Hand Pump Repair Record Contents – 30 minutes

During your repair session, keep the Hand Pump Repair Record nearby to write down the results of your work and other useful observations. Complete the Record before you leave the village. The Record you use in the field will probably get wet and muddy, so plan on re-writing it when you are finished so the Record that you submit will be neat and clean. Your Record must be readable to be of any use.

Many organizations doing pump repair have adopted a record form. If yours does not have one, the example in this lesson includes the information that is useful to the different groups of people to whom you need to report. (There is a blank form in the Appendix that you may reproduce.)

Information that is useful to document includes:

- Details about the village and the people using the well.
- Details on the construction and performance of the well, before and after your repairs.
- Your initial observations on what might be wrong with the pump, what problems you actually found, and what you were able to repair.
- The cost of repairing the pump, which includes transportation, labor, replacement parts, materials such as cement or chlorine, and outside services like a welder.

Your organization will establish procedures for submitting your completed Pump Repair Record to the different people who want the information that it contains. But before you leave the village it is always a good idea to give a copy of your Record to the Water Committee or village leader.

### **Suggestions for completing the Pump Repair Record:**

**Location and GPS:** Be as specific as you can, giving village, district, and state or province names. If you do not have a GPS receiver, estimate the latitude and longitude from an accurate map.

**People served:** This is the number of people who rely on the well for *most of their drinking water*. It may not be the total number of people in the village, especially if there are other water sources. If you are given a very high number of users, ask more questions to get the most accurate estimate you can.

**Repair history:** Knowing what problems the pump has had in the past, how often they occurred, and when they were fixed, can point to problems with well construction.

**Other Notes and Comments:** Use this space to write down any information that you think might be useful to another pump repair technician who may come after you to repair the pump again.



### Table 3 HAND PUMP REPAIR RECORD

Repair date (D/M/Y): \_\_\_\_\_

Village name and location: \_\_\_\_\_

GPS coordinates: \_\_\_\_\_

Well number or other designation: \_\_\_\_\_ Ownership: \_\_\_\_\_

Permission to repair well given by: \_\_\_\_\_ Title: \_\_\_\_\_

Number of people served by the well: \_\_\_\_\_ Number of families served: \_\_\_\_\_

Date Installed: \_\_\_\_\_ Installed By: \_\_\_\_\_

 Is this a:  Borehole? or a  Hand-dug well? Casing or well diameter: \_\_\_\_\_

Total depth of well: \_\_\_\_\_ Depth to water (static level): \_\_\_\_\_

How much seasonal fluctuation? \_\_\_\_\_ meters Highest month: \_\_\_\_\_ Lowest month: \_\_\_\_\_

Type of hand pump: \_\_\_\_\_ Depth of pump intake: \_\_\_\_\_

Is there water in the well? Yes / No When was the pump last working? \_\_

Summary of this pump's repair history:

 \_\_\_\_\_  
 \_\_\_\_\_  
 \_\_\_\_\_

Pump Performance Test results:

Before repair: 40-Stroke Pump Test = \_\_\_\_\_ liters 5 minute Leak Test = \_\_\_\_\_ strokes

After repair: 40-Stroke Pump Test = \_\_\_\_\_ liters 5 minute Leak Test = \_\_\_\_\_ strokes

Describe all repair work completed:

 \_\_\_\_\_  
 \_\_\_\_\_  
 \_\_\_\_\_  
 \_\_\_\_\_

Chlorine Used: \_\_\_\_\_ liters at \_\_\_\_\_% Pump locked? Yes / No Instructions given? Yes / No

Was water quality tested: Before repair? Yes / No After repair? Yes / No (Attach any test results)

Pump Repair Cost Information:

Time spent repairing this pump: \_\_\_\_\_ hours Number of trips: \_\_\_\_\_ Travel time: \_\_\_\_\_ hours

List all parts used: \_\_\_\_\_

List all expenses: \_\_\_\_\_

Other notes and comments:

 \_\_\_\_\_  
 \_\_\_\_\_

Record completed by: \_\_\_\_\_ Signed: \_\_\_\_\_

 Copy of Repair Record given to:  Village Water Committee  Supervisor  Government

**3. Learn From Each Other – (throughout the class)**

During this class you will complete a Pump Repair Record for every well that you work on. You will use your completed records to report to the other students what you learned during your repair sessions. So if they did not encounter that same pump problem themselves, they will be able to learn from your experiences.

Bring your completed pump repair logs and worn parts to the class and be ready to answer as many of these questions as you can:

- Describe what you did – who was involved (entire team?), type of pump, pump malfunctions, what repairs made, were all needed repairs made, repair log completed (translated?).
- What problems – other than broken pumps - did you encounter?
- How did you deal with those problems?
- How did you arrange your transportation?
- What did the repair cost (labor, transportation, parts & supplies)?
- Where did you obtain parts?
- Describe the community – means of employment, size, organization, water committee.
- In what ways did you coordinate your work with the community?
- What ministry opportunities did you have and what were the results?
- In what ways did you feel that the previous class prepared you well for the work?
- Was there anything not discussed in the previous class that we should have covered?

As you listen to the other students relate their experiences repairing different pumps, take careful notes in the spaces provided on the following pages. List the type of pump, what symptoms were evident as the pump was inspected, what the actual problem was, and any other information that will be helpful for to you to remember when you encounter this same problem.

<b>Pump Type:</b>	<b>Flow Rate:</b> Before=	After=
Symptoms: (what was observed?)		
Problems discovered:		
Other notes:		

<b>Pump Type:</b>	<b>Flow Rate:</b> Before=	After=
Symptoms: (what was observed?)		
Problems discovered:		
Other notes:		

<b>Pump Type:</b>	<b>Flow Rate:</b> Before=	After=
Symptoms: (what was observed?)		
Problems discovered:		
Other notes:		

<b>Pump Type:</b>	<b>Flow Rate:</b> Before=	After=
Symptoms: (what was observed?)		
Problems discovered:		
Other notes:		

<b>Pump Type:</b>	<b>Flow Rate:</b> Before=	After=
Symptoms: (what was observed?)		
Problems discovered:		
Other notes:		

<b>Pump Type:</b>	<b>Flow Rate:</b> Before=	After=
Symptoms: (what was observed?)		
Problems discovered:		
Other notes:		

<b>Pump Type:</b>	<b>Flow Rate:</b> Before=	After=
Symptoms: (what was observed?)		
Problems discovered:		
Other notes:		

<b>Pump Type:</b>	<b>Flow Rate:</b> Before=	After=
Symptoms: (what was observed?)		
Problems discovered:		
Other notes:		

<b>Pump Type:</b>	<b>Flow Rate:</b> Before=	After=
Symptoms: (what was observed?)		
Problems discovered:		
Other notes:		

<b>Pump Type:</b>	<b>Flow Rate: Before=</b>	<b>After=</b>
Symptoms: (what was observed?)		
Problems discovered:		
Other notes:		

<b>Pump Type:</b>	<b>Flow Rate: Before=</b>	<b>After=</b>
Symptoms: (what was observed?)		
Problems discovered:		
Other notes:		

<b>Pump Type:</b>	<b>Flow Rate: Before=</b>	<b>After=</b>
Symptoms: (what was observed?)		
Problems discovered:		
Other notes:		

<b>Pump Type:</b>	<b>Flow Rate: Before=</b>	<b>After=</b>
Symptoms: (what was observed?)		
Problems discovered:		
Other notes:		

<b>Pump Type:</b>	<b>Flow Rate: Before=</b>	<b>After=</b>
Symptoms: (what was observed?)		
Problems discovered:		
Other notes:		

<b>Pump Type:</b>	<b>Flow Rate: Before=</b>	<b>After=</b>
Symptoms: (what was observed?)		
Problems discovered:		
Other notes:		

<b>Pump Type:</b>	<b>Flow Rate: Before=</b>	<b>After=</b>
Symptoms: (what was observed?)		
Problems discovered:		
Other notes:		

<b>Pump Type:</b>	<b>Flow Rate: Before=</b>	<b>After=</b>
Symptoms: (what was observed?)		
Problems discovered:		
Other notes:		

<b>Pump Type:</b>	<b>Flow Rate: Before=</b>	<b>After=</b>
Symptoms: (what was observed?)		
Problems discovered:		
Other notes:		

<b>Pump Type:</b>	<b>Flow Rate: Before=</b>	<b>After=</b>
Symptoms: (what was observed?)		
Problems discovered:		
Other notes:		

<b>Pump Type:</b>	<b>Flow Rate: Before=</b>	<b>After=</b>
Symptoms: (what was observed?)		
Problems discovered:		
Other notes:		

<b>Pump Type:</b>	<b>Flow Rate: Before=</b>	<b>After=</b>
Symptoms: (what was observed?)		
Problems discovered:		
Other notes:		



#### 4. Summarize What We Have Learned – 20 minutes

There are four general categories of well or hand pump problems:

**1. Water is not getting into the pump.**

Causes:

---

---

---

---

---

**2. The pump piston or valves are not working well.**

Causes:

---

---

---

---

**3. Pump parts have become separated.**

Causes:

---

---

---

---

**4. The water is contaminated.**

Causes:

---

---

---

---

---



## Lesson 4.1 The Afridev Hand Pump



### Purpose

To introduce the components of an Afridev hand pump.



### Objectives

By the end of this lesson, participants will have

- Reviewed the parts and manner of operation of the Afridev pump.



### Materials

- Poster of Afridev cylinder
- Markers



### Preparation

- Study lesson ahead of time.



### Time

45 minutes



### Steps

1. Afridev Parts
2. Exercise



### 1. Afridev Parts - 5 minutes

Study this drawing of an Afridev pump head and label these parts:

- Cover
- Handle
- Handle bearing
- Pump rod
- Rod hanger
- Riser main.

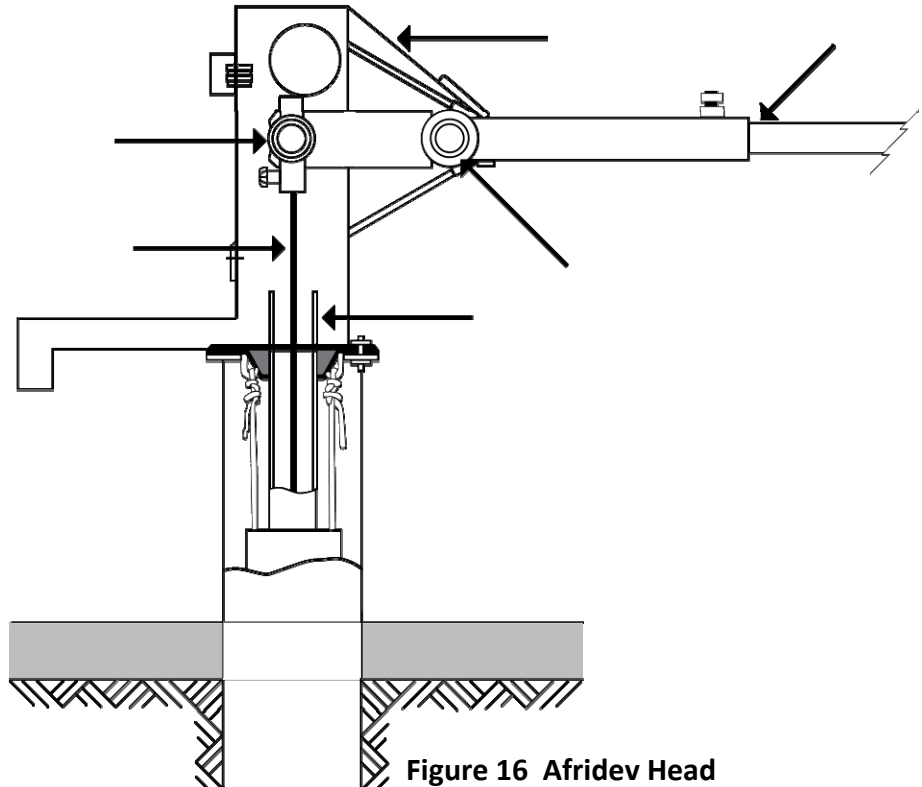

Figure 16 Afridev Head



## 2. Exercise - 40 minutes

When working on an Afridev pump, at least two people should work together; one person alone should not try to repair a pump. So get into teams of two people for this exercise.

Each team will take turns disassembling the pump head and putting it back together. Watch the other teams so that when it is your turn you will know what to do.

First, disassemble the Afridev pump:

1. Remove the pump cover.
2. Loosen the rod hanger nuts and the handle bushing nuts.
3. Slowly lower the pump handle and guide the handle of the Afridev tool through the loop at the top of the rod hanger and rest it on the slots at the top of the pump head.
4. Remove the handle by pulling it straight back.
5. Carefully remove the axles and bushings from the handle and rod hanger. Be sure to examine the bushings for wear.
6. Place all small parts in the pump head cover to keep them clean.

Next, remove the pump rods, piston, and foot valve (if available on “demonstration” pump in the classroom).

Finally, follow the same steps in reverse to put the pump back together again. Make sure the small round pin in the axle lines up with the bump on the nylon bushing.

➤ What step might a villager have difficulty doing?





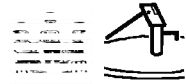

---

---

---



## Lesson 4.2 Afridev Pump Cylinder

	<b>Purpose</b> <i>To introduce the details of an "open top" cylinder</i>
	<b>Objectives</b> <i>By the end of this lesson, participants will have</i>
	<ul style="list-style-type: none"> <li>Examined the components of an Afridev pump cylinder.</li> </ul>
	<b>Materials</b>
	<ul style="list-style-type: none"> <li>Poster of Afridev cylinder</li> <li>Afridev cylinder (option)</li> </ul>
	<b>Preparation</b>
	<ul style="list-style-type: none"> <li>Study lesson ahead of time.</li> </ul>
	<b>Time</b>
	30 minutes
	<b>Steps</b>
	<ol style="list-style-type: none"> <li>Cylinder Components</li> <li>Afridev Cylinder Comparison</li> </ol>

### 1. Cylinder components - 10 minutes

Study this drawing of the Afridev Pump Cylinder. Draw lines from the part names to the correct spot on the drawing.

- Riser Main
- Pump Rod
- Piston (Plunger)
- Traveling Valve
- Piston Seal
- Cylinder Barrel
- Foot Valve Retriever
- Foot Valve
- O-Ring
- Suction Pipe

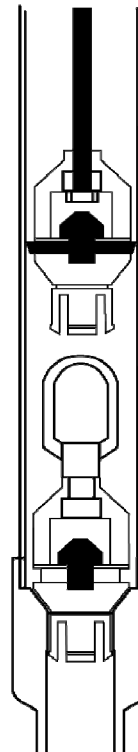

Figure 17 Afridev Cylinder



## 2. Afridev Cylinder Comparison - 20 minutes

Working with your team, consider the following questions. Be prepared to report your conclusions to the rest of the class.

- What are some of the differences between this cylinder and the one pictured in the lesson about “Sylvia’s Pump?”

---

---

---

- How might these differences make repairing an Afridev pump easier or harder than the other type of cylinder?

---

---

---

- Which parts of the Afridev pump cylinder might wear out?

---

---

---

- For each part that you think might wear out, describe how you think it might affect pump performance.

---

---

---









### The “Deep Well” Afridev

The standard Afridev piston and foot valve are made of sturdy plastic. These parts are interchangeable, which reduces the cost of manufacturing. The standard Afridev is designed for wells no deeper than 45 meters (150 feet). It has been found that in deeper installations the weight of the water causes the plastic to fail or the piston seals to fold over. So a “deep well” version has been developed that uses brass pistons and foot valves and larger piston seals (or two seals). On this design the bottom of the piston has threads that screw into the top of the foot valve, so the foot valve can be retrieved after the rod hanger has been removed from the handle. A separate foot valve retrieval tool is not needed. A deep well Afridev usually has an identifying tag on the pump base.



## Lesson 4.3 Afridev Pump Adjustment

	<b>Purpose</b> <i>To learn the proper technique to adjust the stroke length of the Afridev cylinder.</i>
	<b>Objectives</b> <i>By the end of this lesson, participants will have</i> <ul style="list-style-type: none"> <li>• Gained experience in adjusting and correcting a common Afridev installation error.</li> </ul>
	<b>Materials</b> <ul style="list-style-type: none"> <li>• None</li> </ul>
	<b>Preparation</b> <ul style="list-style-type: none"> <li>• Study lesson ahead of time.</li> </ul>
	<b>Time</b> 40 minutes
	<b>Steps</b> <ol style="list-style-type: none"> <li>1. A Pump Repair Situation</li> <li>2. Continue your investigation</li> <li>3. Proper pump rod adjustment</li> </ol>

### 1. A Pump Repair Situation - 10 minutes

Imagine that you have just arrived in a village to repair their pump. The head of the Water Committee tells you that every time they try to pump water, they have to pump a long time to get the water to come out. Once it starts to flow, all is fine. Later, when someone else tries to get water, they also have to pump a long time before water comes out. They want you to fix it.

Working with your team, discuss the following questions about this pump repair situation. After about 5 minutes we will come back together to share our ideas with the class.

➤ What do you think is the problem with this pump?

---



---



---



---



## 2. Continue Your Investigation... - 10 minutes

If something is wrong with an Afridev pump, other than a problem in the pump head, one of the first things to do is to pull out the pump rods, piston (plunger), and foot valve. This is very easy to do on an Afridev.

So, upon removing these parts, you inspect them but cannot find anything that appears wrong. The valves are good and the seal and O-ring are not worn out. You test the piston using a spare Afridev cylinder in a bucket of water and it works fine.

➤ What else might be causing the reported problem with the pump?

---

---

---



## 3. Proper Pump Rod Adjustment - 15 minutes

The distance that the piston moves up and down in the pump cylinder is called the “pump stroke.” The length of the pump stroke is determined by the distance that the front end of the pump handle travels with each stroke. The upper and lower limits are set by stops built into the pump housing.

The pump rod is connected to the handle, so the length of the pump rod determines the section of the pump cylinder in which the piston moves up and down.

If the rod is too short, the piston moves in the upper portion of the cylinder. The piston might travel above the cylinder where the seal is not as tight so that some water will get past the seal on each stroke.

If the rod is too long, the piston moves in the lower portion of the cylinder. In this case the piston might hit the foot valve and damage it.

It is necessary to cut the top pump rod to the proper length so that the piston stays inside the pump cylinder and does not hit the foot valve. For this reason, Afridev pumps are usually supplied with one pump rod that does not have a “loop” coupling on one end.

If the pump was installed with a rod that is too long, then mark it at the proper length and cut it off as described below. If the rod is too short, then replace it with a new rod cut to the proper length. (Save the old rod.)

If one part of the pump cylinder has become worn, then the rod can be slightly shortened (or lengthened) to use a section that has not been worn.

To determine where to cut the pump rod:

1. Install the foot valve and piston and let the piston rest on the foot valve.
2. Grasp the pump rod even with the top of the riser main.
3. Without moving your finger from that spot, get some help to lift the rod so that you can place a permanent mark there.
4. Pull out the top section of rod and cut it at the mark with a hack saw.
5. Re-attach the pump rod to the rod hanger.

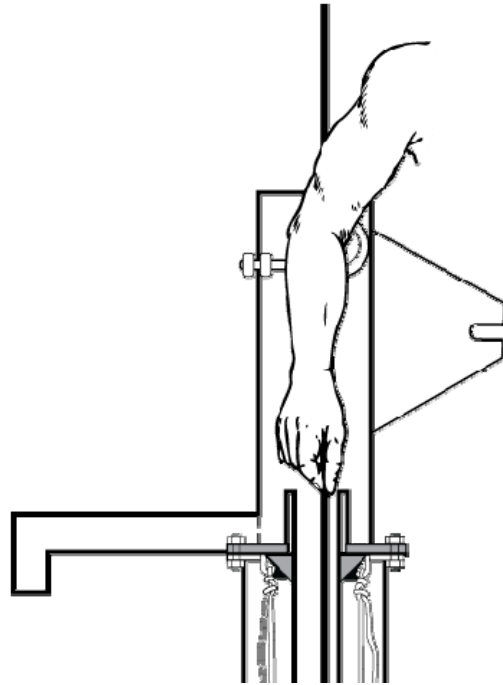

**Figure 18 Afridev Adjustment**

Think back to the pump repair problem we started with in this lesson. It did not look like the piston or foot valve were damaged. But if the pump rod was too long, the piston might have been hitting the foot valve nearly every stroke. The plastic is very hard, but with a closer look, we might see evidence of damage.

But the real damage is being caused to the seat at the bottom of the cylinder where the foot valve rests. If the foot valve assembly is hit hard enough and often enough, this seat can be pushed out so that the O-ring around the foot valve will leak and let water drain out of the riser main. We can't see that problem without pulling out the entire riser main and cylinder.

Pulling the riser main is a lot of work, so you want to be sure it is necessary.

- How would you test whether the pump rod was hitting the foot valve?

---

---

---





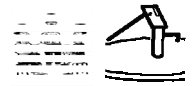

## Lesson 4.4 The India Mark II and Mark III Hand Pumps



### Purpose

To gain the skills to fix common problems with the India Mark II and III hand pumps.



### Objectives

By the end of this lesson, participants will have

- Examined the parts of the India Mark II and III pumps.
- Taken apart and reassembled an India Mark II and Mark III pump.



### Materials

- Mark II poster
- Mark II & Mark III cylinders, at least one for each team



### Preparation

- Study lesson ahead of time.



### Time

60 minutes



### Steps

1. India Mark II & III Pump Head
2. Mark II versus Mark III
3. The Purpose of a "Lock Nut"
4. Mark II and Mark III Cylinder Adjustment
5. Exercise



### 1. India Mark II & III Pump Head - 10 minutes

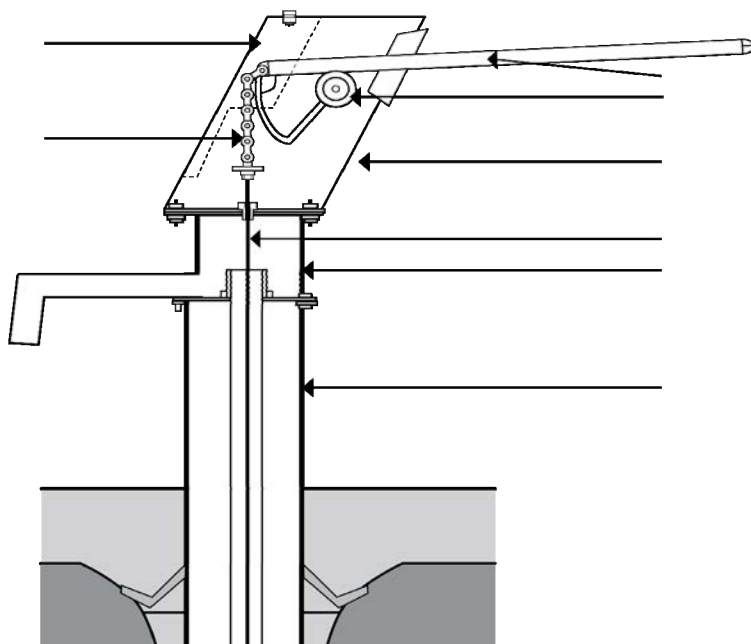

Study this drawing of an India Mark II or Mark III pump head and label these parts:

- Handle
- Handle Axle
- Cover
- Chain
- Top Head
- Water Tank
- Pump Rod

**Figure 19 Mark II or III Head**



## 2. Mark II versus Mark III - 5 minutes

The India Mark II pump is one of the most widely used hand pumps around the world. But it is not suited for village level operation and maintenance (VLOM) because, being a closed-top cylinder, the riser main and cylinder have to be pulled out of the well to service the piston seals and other components that tend to wear out over time.

In response to this problem, the India Mark III pump was developed. The Mark III pump is identical to the Mark II except, like an Afridev, the Mark III riser main is the same diameter as the pump cylinder. This allows the piston and foot valve to be serviced without pulling the riser main. When first introduced, the Mark III had a galvanized iron riser main. Due to the extra weight of this larger pipe, pulling the riser is very difficult. Current models of the Mark III are supplied with PVC riser. Two different cylinder/riser main diameters are available; 50 mm (2") and 65 mm (2.5"). Of these, the 65 mm is more popular.

Of the pump head parts, only the Mark III water tank is different from the Mark II, but they have the same bolt spacing. Therefore, it is easy to convert an existing Mark II pump into a VLOM Mark III pump by replacing the water tank and riser main. With a proper top cap some Mark II cylinders can also be converted to an open-top design (but the foot valve can't be easily removed).

The PVC riser main for both cylinders can be attached to the pump head with an adaptor plate and rubber ring nearly identical to that used on the Afridev pump. There is also a threaded coupling to which a galvanized steel riser main can be attached.

**Note:** the 50mm (2") brass Mark III piston will work in an Afridev cylinder, but the Mark III foot valve will not properly seat in the Afridev cylinder.



## 3. The Purpose of a "Lock Nut" - 10 minutes

Often, a nut will become loose and slowly unscrew itself from the threads of a bolt. By placing another nut, called a "lock nut" or "jam nut" onto the bolt, and tightening it to the other nut, the nuts cannot become unscrewed from normal jolting and shaking, but are still easily unscrewed with a wrench. Using a lock nut ensures that the bolts or pump rods will not unscrew themselves.

**Always\*** place a lock nut in the following 4 places:

1. On the threads of the piston rod, where it meets the pump rod.
2. On both sides\* of the coupling between two connecting pump rods.
3. On the top pump rod, where it meets the chain assembly.
4. On the bolts that hold the pump head and tank.

\*Only one lock nut is needed on pump rod with welded couplings.



#### 4. Mark II and Mark III Cylinder Adjustment - 5 minutes

If the cylinder wall has become worn so that even a new piston seal has some leakage, the pump rod can be shortened or lengthened so that the piston works a higher or lower section of the cylinder. However, before making this adjustment check to make sure that the cylinder barrel is long enough. If the cylinder barrel is only slightly longer than the stroke length, then this adjustment will not be possible.



#### 5. Exercise - 30 minutes

Each team will take turns disassembling the pump head and putting it back together. Watch the other teams so that when it is your turn you will know what to do. It takes three people to safely lift a Mark II cylinder using C-wrenches. Two experienced people can do it safely using a tripod.

To disassemble and pull the India Mark II pump:

1. Remove the pump cover.
2. Lower the handle and insert the chain support tool under the chain.
3. Remove the bolts that attach the chain to the handle. (Lift the pump rod by the chain to test if the rod might be detached.)
4. Remove the handle axle, using the axle punch to protect the threads, and take out the handle. (The head can be removed with the handle still attached if it is obvious that the axle is in good condition.)
5. Remove the top head flange bolts.
6. Lift the top head using a C-wrench between the access holes.
7. Fit the pump rod vise onto the water tank (below the top head) and clamp the pump rod securely.
8. Remove the chain and chain lock nut from the pump rod, then lift off the top head.
9. Attach a T-Handle securely to the top of the pump rod.
10. Remove the bottom flange water tank bolts and pump rod vise. Using the lifter pipe and C-wrenches, remove the water tank. (If the riser main is separated then the T-Handle will keep it from dropping into the well.)
11. ALWAYS keep a coupling on the upper end of the riser main and the upper end of the pump rod in case they slip through the clamps. (Keep extras in the tool box for this purpose.)
12. Reattach the rod clamp or vise below the water tank.
13. Remove each section of riser main and pump rod. Keep a T-Handle securely attached to the pump rod and make sure the riser is tightly clamped whenever it is not being lifted.

Follow the same steps in reverse to put the pump back together again. Make sure each riser main coupling is tight and rod section is secured with a lock nut. (The T-Handle is not needed when re-installing the pump, since you now know that the riser main is not separated. However, to strengthen this good habit, it is wise to always attach a T-handle even when re-installing the pump.)

Do a final inspection of the pump, making sure that all nuts are tightened, there is a lock nut on the chain, the chain spacer has been removed, and the cover is properly seated.

➤ Which steps might an untrained villager have difficulty doing?

---

---

---



## Lesson 4.5 Fishing



### Purpose

*Introduce the principles for getting a fallen tool or pump part out of a well.*



### Objectives

*By the end of this lesson, participants will have*

- distinguished what to do if a tool or pump part falls down an open borehole
- practiced common “fishing” techniques.



### Materials

- Sample fishing tools.
- Tools, pump rod, and riser main as “fish.”
- Mock well for each team – 4” PVC casing with a bottom cap and lashed to the side of a pickup truck.



### Preparation

- Gather the fishing tools.
- Set up “mock wells.”
- Gather tools as “fish.”



### Time

90 minutes



### Steps

1. Four Keys to Success
2. Equipment
3. Practice



### 1. Four Keys to Success - 15 minutes

“Fishing” – as applied to pump repair – is the art of retrieving a tool or a pump part that has fallen into the well. Fishing is an essential pump repair skill.

**1. Know your fish.** The first key to successful fishing is to know something about your fish. What is down there, and what does it look like? Is there a coupling or a nut, exposed threads, or a clean break? Look at the remaining end of the rod or riser pipe. Which end of the tool is pointing up? These clues will tell you what kind of fishing tool is likely to work. If there is an unknown object in the well, use soft wax or plasticine attached to the end of a pump rod to make an impression of it.

**2. Have Patience.** When it seems like you will never get it out and are about to give up, consider how much work went into drilling the well. Until you put that much effort into retrieving whatever has been dropped into the well, you have not tried hard enough.

**3. Be Creative.** A good pump technician makes his own fishing tools. It is possible to purchase commercially-made fishing tools. However, most well drillers and pump repairmen make their own fishing tools to meet the current need using whatever is available. Some basic tool types are introduced in this lesson but they are just a start. Never throw away a fishing tool that you have made; you will probably need it again.



**4. Think it through.** The fourth key to successful fishing is using your head. If you can't retrieve the fish, consider if there is enough water in the well so that a new pump can be installed above it. However, if the lost part will rust or cause other problems with the well, then keep fishing.





 **2. Equipment - 15 minutes**

If you have ever made a successful fishing tool, describe for the class how it worked.

There are many different kinds of fishing tools. Examine the sample fishing tools or study the pictures below. Try to imagine how they are used, and write what pump parts or tools could be retrieved with each fishing tool.

**Figure 20 Fishing Tools**

Name	Picture	Description and Uses
Overshot Trap		A cylinder that is open at the bottom and attached to a pump rod (or riser main). Inside is a "trap" that slips over the end of a separated riser or a pump rod that allows movement in only one direction. But if the fish can't be pulled out of the well, there is no easy way to disconnect this tool.
Bell		Top of a 2-liter plastic bottle with a rod coupling fitted into the cap. Good for threaded rod with no end nut. The "bell" shape directs the threaded rod end into the coupling.
Half-Moon		A metal disk with a slot cut in to it that starts wide and gets narrower. Attaches to a pump rod. When the lost rod is leaning against the casing wall, rotating this fish will grab the rod. Can grip galvanized rod even without a nut. Stainless steel rod is more difficult to catch unless there is a nut or exposed threads. A larger version can be made for fishing out a broken riser main.

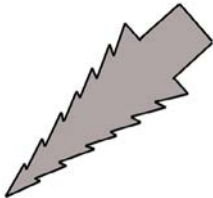
Corkscrew		A spring attached to a rod coupling. Rotating the pump rod twists the spring into the fish. Very useful for retrieving tools such as a pipe wrench.
Hook		A steel rod bent to a sharp hook and welded onto a pipe or rod coupling. Useful in many situations. Can catch the lower lip of a pipe coupling or hook into a tool. Can also be pushed into a pipe.
C-Hook		A design based on the way a wrench “bites” into a riser pipe when used for lifting. It is lowered over the riser with the white rope. Because it is not rigidly attached, it easily slides over the riser. When in place, pulling up on the black rope causes the hook to firmly grip the pipe. Stronger rope can be used for a heavy lift.
Magnet		A magnet will attach to any iron or steel object that has fallen into the well.
Spear		Piece of steel cut with notches that can catch on the threads of a coupling or the rough inside edge of a pipe. Usually attached to a pump rod.

 **3. Practice - 60 minutes**

In your teams, take turns using the different fishing tools to retrieve riser pipe, rods, and tools in the practice well casings.







## Lesson 4.6 Cutting and Threading Steel Pipe



### Purpose

The ability to cut and thread steel riser main is essential to the capacity to fix a broken hand pump.



### Objectives

By the end of this lesson, participants will have

- Practiced cutting and threading steel riser main pipe.
- Considered cutting and threading pipes of other material than steel.
- Evaluated a method of protecting pipe from harsh water.



### Materials

- Riser main pipe
- Tools: Pipe vise, pipe cutter, pipe threader (handle & 1.25" die), reamer or round file.



### Preparation

- Cut 2 ft. segments of pipe



### Time

105 minutes



### Steps

1. Cutting Pipe
2. Threading Pipe
3. Other kinds of Pipe
4. Protecting Pipe from Rust



### 1. Cutting Pipe – 30 minutes

#### Pipe Vise

The pipe vise is used to securely hold the piece of pipe being cut. Place the practice pipe in the pipe vise, leaving enough room at the end for the cutting tool to rotate. Notice how the hook at the end allows you to open the vise completely. This is very handy when working with a long piece of pipe. Tighten the vise so the pipe will not rotate.

Some versions of the Mark II tool kit include a riser main clamp that can be mounted on the pump base (after removing the pump head) as a pipe clamp. When using the pump base in this way, be sure to cover the pump base so that metal shavings and oil do not fall into the well.



Figure 21 Pipe Vise

### Pipe Cutter

Working with your team, take out the pipe cutting tool from your tool box. Turn the handle to see how it raises and lowers the guide wheels. Tightening the handle presses the pipe against the cutting wheel. You cut pipe by rotating the tool around the pipe, tightening the knob a small amount each turn.

Mark the pipe a short distance (about 5 cm) from the end. Practice lining up the cutting tool on the mark where you want to cut.

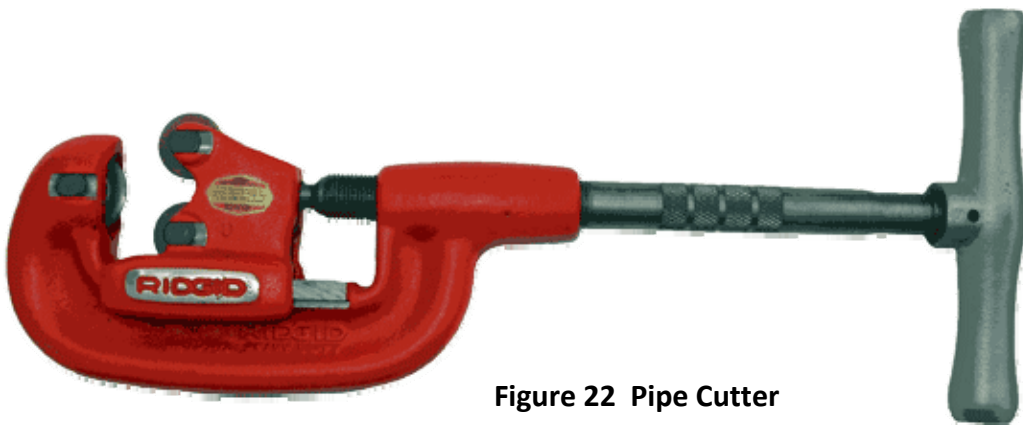

Figure 22 Pipe Cutter

### Practice Cutting

Now practice cutting the pipe where you marked it. Don't try to cut too fast; it will probably take ten or more turns to cut the pipe. Add a small amount of oil to the cut will make it work easier. Take turns so that each team member makes a cut.



Figure 23 De-burring Tool

When the piece of pipe has been cut off, look into the ends. Notice that a ridge has formed inside the pipe at the cut point, so that the walls are no longer smooth. This ridge is called a "burr" and it is important to remove it. This is done either with a de-burring tool (also called a reaming tool) or with a file. Practice de-burring the section of pipe held in the vise.



## 2. Threading Pipe - 60 minutes

Examine the pipe threading tool. Notice that it has two main parts; the handle and the “die.” The die can easily be removed from the handle. Notice the teeth inside the die. These are what cut threads in the pipe; the teeth can be replaced when they get dull.

- With the pipe firmly held in the vise, fit the threading die over the end of the pipe. The unthreaded side of the die goes onto the pipe first, as a guide. Make sure the die is square, not at an angle to the pipe.

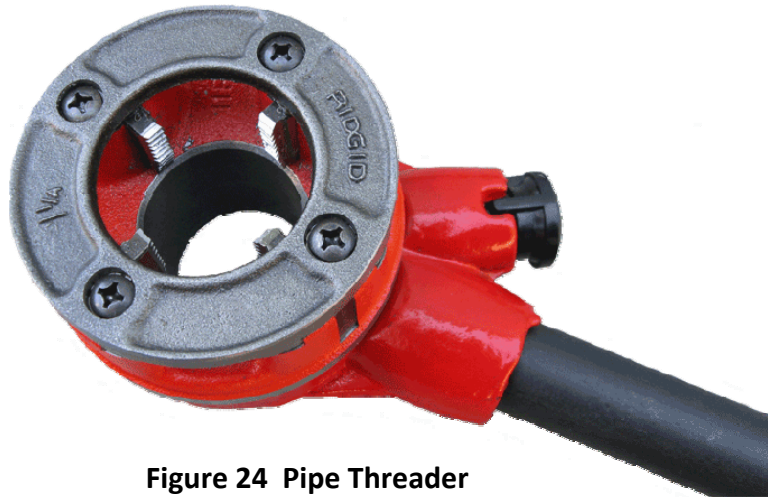

Figure 24 Pipe Threader

- Add cutting oil to the teeth then slowly turn the die handle clockwise. After about half of a turn, back the die up a little bit so the cuttings can drop out.
- Continue cutting, backing off every half-turn, and frequently adding a few drops of oil. Stop cutting thread just short of the width of the die.
- Back the die off of the pipe, wipe off any oil, then remove the pipe from the vise and knock out any cuttings from inside the pipe.

Let every team member have a turn at threading the pipe.



## 3. Other Kinds of Pipe

The pipe cutter, threader, and reamer used in this lesson are designed for steel pipe. They will not work on PVC pipe or copper tubing because these types of pipe have thin walls and are much weaker than steel.



#### 4. Protecting Pipe from Rust - 15 minutes

Often, when a section of riser main needs to be replaced it is because it has holes or pits from rust (corrosion). If this is the case, then the replacement pipe should be protected from rusting so the same thing does not happen to it.

The easiest way to protect steel pipe from rusting is to wrap it with tape. Two types of tape will work. Plumbing supply shops often carry a wide, black PVC tape that is made for wrapping pipe. If that tape cannot be found, then plastic electricians' tape will also work. Electrical tape is available in most hardware shops.

Wrapping the pipe keeps water from getting to it, so it can't rust. Rust normally starts from the outside and works in. So wrapping the outside of the pipe is enough to protect it. The tape should cover the entire riser main that is under water. Because couplings are usually thicker than pipe, they do not need to be wrapped but the tape should overlap the coupling to protect the pipe threads.

PVP pipe wrapping tape comes in many different widths but electrical tape is usually about 3/4 inch (19 mm) wide. The tape should be wrapped so that each layer overlaps the one above it by about 4 or 5 mm.

It will take about 9 meters of electrical tape to wrap one meter of standard 1-1/4 inch riser main (about 6.6 feet of tape per foot of pipe). That works out to about 27 meters of tape needed to cover a 3-meter length of riser main. This is about 3 small rolls of electrical tape.

Prices will vary from country to country, but electrical tape is a tiny fraction of the cost of riser main. So this is a very economical way to protect riser main from rusting.

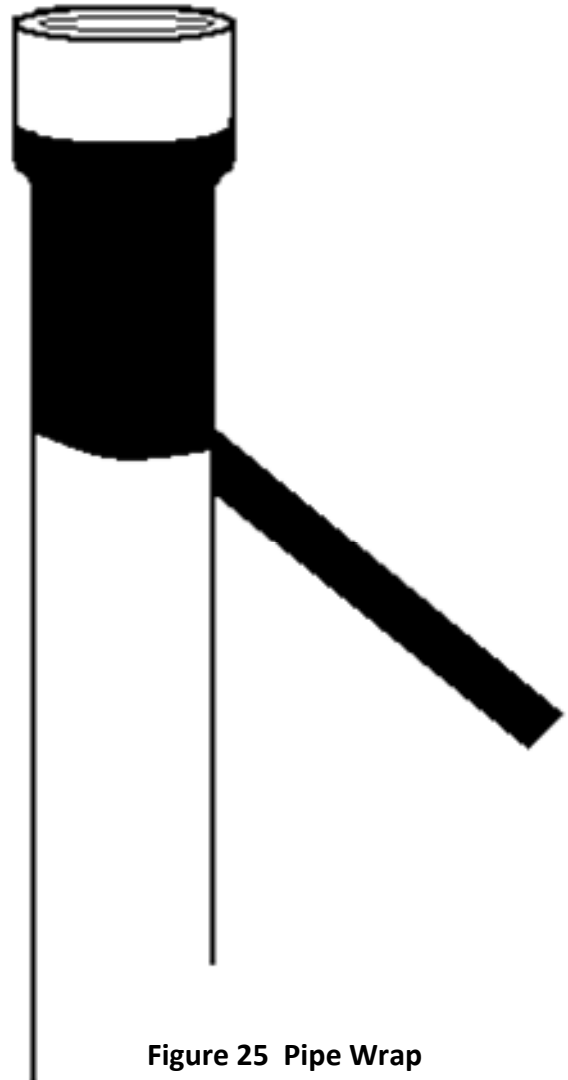







Figure 25 Pipe Wrap



## Lesson 4.7 Cutting and Threading Pump Rod

	<b>Purpose</b> <i>Practice cutting and threading steel pump rod to obtain straight threads.</i>
	<b>Objectives</b> <i>By the end of this lesson, participants will have</i> <ul style="list-style-type: none"> <li>• Practiced the correct techniques for cutting and threading steel pump rod.</li> </ul>
	<b>Materials</b> <ul style="list-style-type: none"> <li>• Pump rod for each group</li> <li>• Tools for each team: hack saw, die and handle, file, pump rod clamp</li> </ul>
	<b>Preparation</b> <ul style="list-style-type: none"> <li>• Have one set of materials handy for a quick demonstration of the technique.</li> <li>• Set out materials for each team to collect.</li> </ul>
	<b>Time</b> 60 minutes
	<b>Steps</b> <ol style="list-style-type: none"> <li>1. Cutting and Beveling Pump Rod.</li> <li>2. Threading Pump Rod.</li> <li>3. Practicing Cutting and Threading Rod.</li> </ol>

### 1. Cutting and Beveling Rod - 10 minutes

When it becomes necessary to cut and thread a steel pump rod it usually involves a length adjustment where the rod connects to the pump handle. It is necessary to first install the rod in the well to get the proper length. By raising and lowering the pump piston, you can set the rod length so the piston does not hit either the bottom or the top of the pump cylinder. The steps to follow are:

1. Mark the rod at the proper length for the pump. This will depend on the type of pump and cylinder.
2. With the rod still in the well, secure it tightly with a rod clamp and secure the clamp to the pump housing. Pack rags around the clamp so that tools, metal shavings, or oil can't fall into the well.

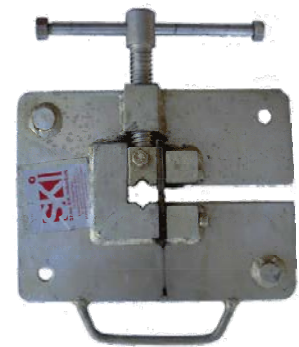

**Figure 26**  
**Rod Clamp**

- Using a hack saw cut the rod at your mark. It is very important that the cut be level, or the threads will not come out straight.



**Figure 27  
Hack Saw**

- Using a metal file, bevel the end of the rod as shown in the drawing on the right. The threads will not come out straight if the bevel is not even all the way around the rod. It will take time to get it right so work carefully.

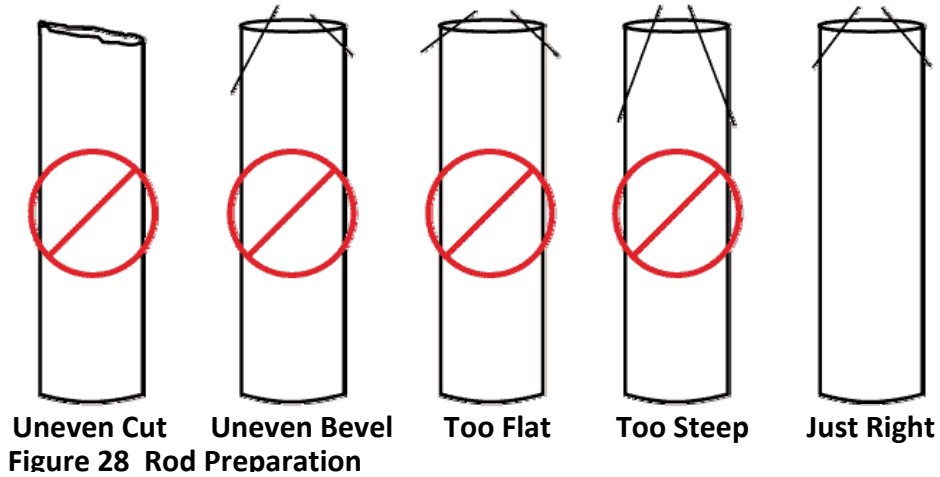

 **2. Threading Rod - 10 minutes**

*This is best practiced on a well. Otherwise one or two students can hold the rod clamp while another is threading the rod. Use pieces of rod no more than 1 foot long. Demonstrate the procedure to the class as you are explaining it.*

The threading tool has two parts; the handle and the die. The handle can hold several different sizes of die depending on the rod diameter and thread size.

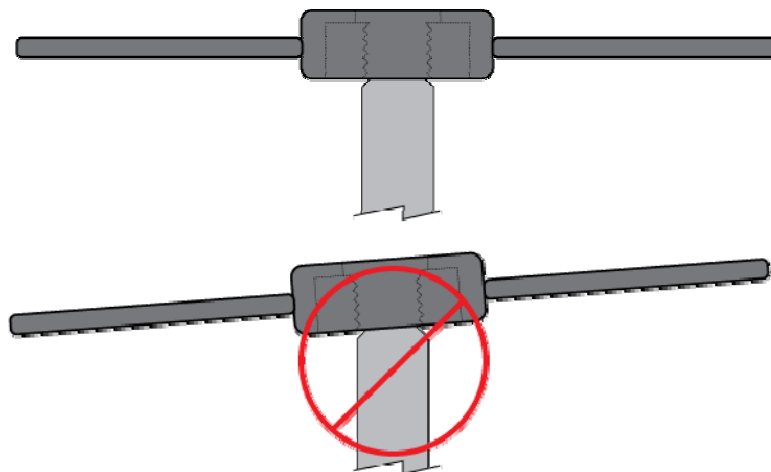

**Figure 29 Threading Tool Alignment**

It is very important to make the threads even. This is achieved by keeping the threading tool **perfectly perpendicular** to the rod.

Having crooked threads on a pump rod is not good:

- It causes one side of the rod to be stressed which could cause it to break.
- It causes a bend at the coupling which could rub against the inside of the riser main and make a hole in it.

### Rod Threading Procedure:

1. Look at the way the die sits on a ledge in the handle. Hold the die against the rod so that when you press down, the die is pushed against that ledge, not away from it.
2. Slowly rotate the threading tool around the rod while exerting downward pressure. Keep the tool **perpendicular** to the rod.
3. When the cutting teeth begin to “bite” add a few drops of **oil**.
4. After every 2 or 3 full turns of the tool, back up about half a turn to clear out the cuttings. Add a few more drops of oil each time you back up. Repeat this.
5. Keep cutting threads until the end of the rod begins to come out the top of the die then **back** the tool off of the rod.
6. Inspect the depth of thread all around; if one side is deeper than the other side, then the threads are not straight. It is easiest to see if they are crooked by looking at the base of the threads. Crooked threads will be cut in deeper on one side of the rod, leaving a shoulder. Straight threads will not have such a shoulder. Even slightly crooked threads can cause the pump rod to eventually break.
7. If the threads are too crooked, cut off the threaded section and try again. If this causes a problem with the stroke length, then a new section of rod might be needed.



Figure 30 Thread Quality

### 3. Practice Cutting and Threading - 40 minutes

In your teams, take turns cutting and threading a short piece of pump rod. In this exercise, we won't be working over a well so someone will need to hold the rod clamp to keep it steady. Keep practicing until you can get the threads straight.





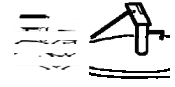

## Lesson 4.8 Working With PVC Pipe



### Purpose

To gain knowledge and skills required for the proper use of PVC pipe.



### Objectives

By the end of this lesson, participants will have

- Practiced cutting and gluing PVC riser main pipe.
- Seen other uses for PVC pipe



### Materials

- Bell & socket PVC pipe or straight pipe with couplings.
- Tools: hack saw, fine sandpaper, PVC cement.



### Preparation

- Study lesson ahead of time
- Lay out pipe and tools for each team



### Time

90 minutes



### Steps

1. Choosing the Right PVC Pipe
2. Handling PVC Pipe
3. Other Uses
4. Practice



### 1. Choosing the Right PVC Pipe– 30 minutes

PVC pipe has advantages over galvanized iron (GI). It is less expensive, much lighter, very easy to work with, and does not rust. The main disadvantage is that PVC is not as strong as GI pipe. But when properly joined, the advantages of PVC outweigh this disadvantage. (PVC and uPVC are similar, but uPVC tends to be more rigid and have better resistance to sunlight.)

For well construction, it is important to always use strong PVC (or uPVC) pipe for the casing or, with a VLOM hand pump, for the riser main. Never try to use thin-walled drain pipe in a well because it can not withstand the pressures and will collapse or break.

Several grades of PVC (or uPVC) are available in most countries. “Schedule” is the universal term used to describe PVC pipe strength. Thin-walled drain pipe, not suitable for use in a well, is rated Schedule 20 or lower. Heavier-walled PVC that is suitable for use in a well is rated Schedule 40. PVC pipe designed for high pressure applications is rated Schedule 80. It is not necessary to use Schedule 80 PVC pipe in a shallow well.

Some suppliers do not use the “Schedule” system, but instead rate their PVC pipe according to the amount of pressure that it can hold. If neither the Schedule nor the pressure rating is known, then wall thickness can be used as a guide to PVC pipe strength. The following table lists these different strength ratings for Schedule 40 PVC pipe in three common diameters. (Note: “Nominal diameter” refers to the inside diameter of PVC pipe. “Nominal” means that it is not the precise diameter, but has been rounded off for convenience.)

**Table 4 Schedule 40 PVC Strength Ratings**

Nominal Diameter	Pressure Rating	Wall Thickness
50 mm (2")	9 bars (280 psi)	4 mm (0.15")
65 mm (2.5")	20 bars (300 psi)	5 mm (0.20")
100 mm (4")	15 bars (220 psi)	6 mm (0.24")

It is not unusual for a supplier to carry two grades of PVC in the same size, with each grade having approximately the same wall thickness. The only apparent difference is the price. If there is no other indication of the pipe’s strength rating, then purchase the more expensive grade of pipe. This will be a bargain in the long run, because it is either impossible or very expensive to repair a well if the casing has collapsed. A water well can supply safe water to many people for a very long time, so it is wise to use the best available materials in its construction.

A PVC pipe purchase can get even more complicated due to different measurement standards used in the countries that manufacture PVC pipe. In the United States, English units are used. Most of the rest of the world uses metric (SI) units. The difference in pipe diameters between these two systems is not simply the conversion between millimeters and inches (25.4mm=1"). There may be several millimeters difference between pipes of the same nominal diameter. This difference can be critical if one is trying to join two pipes from different sources, or fit a pump designed for one system into a casing made under the other system. The following table is a helpful guide when looking for a specific dimension of PVC pipe.

**Table 5 Metric & English uPVC Pipe Sizes**

Nominal inch diameter	Metric Standards		English Standards	
	Outside Diameter	Approx Inside Diameter	Outside Diameter	Approx Inside Diameter
1.5"	40 mm	33 mm	48.1 mm	40 mm
2"	63 mm	55 mm	60.2 mm	52 mm
2.5"	75 mm	65 mm	75 mm	65 mm
3"	90 mm	80 mm	88.7 mm	78 mm
4"	110 mm	98 mm	114.1 mm	102 mm
5"	125 mm	116 mm	140 mm	130 mm
6"	160 mm	148 mm	168 mm	154 mm
8"	225 mm	210 mm	219 mm	204 mm

Adapted from: “Drilled Wells” Peter Ball, SKAT, 2001



## 2. Handling PVC Pipe – 20 minutes

**Storing.** Both PVC and uPVC pipe are damaged by being stored in open sunlight for long periods of time. Therefore, either store the pipe under a roof or cover it with a tarp. Support the pipe on boards, using at least one board for every meter of pipe. Stack the pipe neatly, in no more than 4 layers so that the lower pipes are not damaged.

**Cutting.** PVC and uPVC pipe is easily cut using a common hand saw. A hack saw will also work, but pipe larger than 2" in diameter will need to be rotated to cut all the way through. Keep the saw blade straight to get a flat end. Support the pipe on boards to keep it clean.

Cutting PVC produces a lot of scraps inside the pipe. Most can be removed by wiping the edge with a clean cloth or by tipping the pipe and shaking them out. When cutting well screen, it is necessary to "swab" the inside of the pipe using a clean cloth tied to a rope. Pull the cloth back and forth until all of the scraps have been knocked loose. If not removed, these scraps can cause the pump to malfunction.

**Joining.** PVC pipe is sold in either straight sections or with a "bell" end. Straight pipe requires a coupling to be added at one end. Bell end pipe has a coupling built into one end. When purchasing bell end pipe, it is wise to also purchase a few couplings so that short sections of pipe without a bell can be joined.

**Cleaning.** Before gluing PVC pipe it is very important to thoroughly clean the surfaces that will be glued. Lightly sanding the surfaces with fine sandpaper will make a stronger connection. Some PVC glues work best if a "primer" is applied first.

**Gluing.** The technical term for PVC glue is "solvent cement." This is because the "glue" actually dissolves the surface of the PVC where it is applied. When it dries, the joint can be stronger than the original PVC. The surfaces to be joined must be clean and completely dry before applying glue.

Before applying glue, check the fit by inserting the straight end into the coupling or bell end. They should be very tight. If you can easily insert the pipe all the way into the back end of the coupling or bell, without glue, then the fit is too loose to be joined. This can happen if the PVC came from different sources.

Apply a light coat of solvent cement to the inside of the coupling or bell and to the end of the straight section. Then quickly push the two pieces together, giving them a ¼ turn as you push. The glue will lubricate the pipe so that it will go in farther than when it is dry.

This should be done by two people, pushing against each other. Remember to quickly screw the top of the glue can back on tightly or the glue will evaporate or get spilled.

**Drying.** Once the PVC pipe has "bottomed-out" in the bell or coupling, do not move it. Hold it still for at least 5 minutes. Some solvent cement requires a longer drying time.



### 3. Other Uses – 10 minutes

PVC is a very useful material since it is easy to cut and it can be softened with heat and shaped. If the shape is held until the PVC cools it will hold that shape. A 4-inch diameter PVC pipe has a wall thickness of around 12 mm (0.5"). Flattened out, it will be around 35 cm (14") wide.

To get a flat piece of PVC, cut off a section of pipe and then cut along its axis. Slowly heat the pipe over a fire and as it softens, gently open it up flat. Holding it too close to the fire and heating it too fast will burn the PVC and make it brittle. Once it has been opened up, place it between two boards and set heavy rocks on top or clamp the boards together. It will stay flat after it cools.

This flat piece of PVC can be used to make a lot of things. For example, use a hole saw to make the round disk that is part of a bailer (Appendix 6) or supports for the piston seal on a home-made pump cylinder.



### 4. Practice – 30 minutes

Working in your teams, practice cutting, cleaning, and gluing two pieces of PVC pipe. If time and circumstances allow, practice making a flat piece of PVC.



## Lesson 5.1 Protecting the Well



### Purpose

*Recognizing that the condition of the pump pad and surrounding area has a significant effect on the quality of the well water.*



### Objectives

*By the end of this lesson, participants will have*

- Considered the effects of a poorly constructed or damaged pump pad.
- Identified and practiced ways to restore a pump pad.



### Materials

- Poster of broken and dirty pump pad.
- Poster of repaired pump pad.
- Cement, sand, and gravel in 1:2:3 ratio – each team should have 2-3 liters of cement and proportionate amounts sand and gravel to mix.
- Buckets, shovels, and trowels for each team.
- Sufficient board or bricks to make concrete forms about 1 foot (30 cm) square.
- Water



### Preparation

- Locate areas of damaged concrete near the classroom that the class can repair.
- Alternately, identify a spot where stepping stones would be useful and have each team make one step.
- Get permission to make concrete repairs or steps!
- Gather materials for students to measure out.



### Time

105 minutes



### Steps

1. The Effects of a Damaged Pump Pad.
2. Use Concrete to Restore a Pump Pad.

*Don't be shy about taking on a "Story Teller" persona; use different voices for the characters. You will alternate between the story and the teams discussing questions among themselves. So the teams should sit so they can turn their attention back to the facilitator without having to move much.*



### 1. The Effects of a Damaged Pump Pad - 45 minutes

***Please listen to this story...***

A long time ago in a country far away there was a village called Beersheba. Throughout the area, everyone knew that the people of Beersheba were proud, kind, and intelligent. "After all," they would say, "Beersheeba was the first town in our area to install a well with a hand pump."

With their hand pump, the people of Beersheeba had enough water to drink, wash, grow crops. There was also enough water for their livestock so there were many animals around the town. One resident of Beersheeba, a bright young man named Abimelech, owned land near the village hand pump. Every morning and every evening he would bring his animals to the well and pump water for them. Sometimes he would see the other villagers there with their livestock and they would discuss how happy they were about their well and the ways it made life better.

One morning as Abimelech was bringing his livestock to drink, he saw Phicol, who lived in a nearby village, drawing water for his animals. "Greetings!" shouted Abimelech, but his friend only waved weakly. Abimelech thought to himself, "I wonder why Phicol is not using the pump in his own village that I helped him install?"

As he came closer, Abimelech was surprised to see his neighbor looking pale and weak. "Phicol, are you well?" asked Abimelech. "No," Phicol replied, "My whole family is sick, as are many of our neighbors. I was up all night tending to my sick children. Some say the water from our hand pump has gone bad and others say it is cursed."

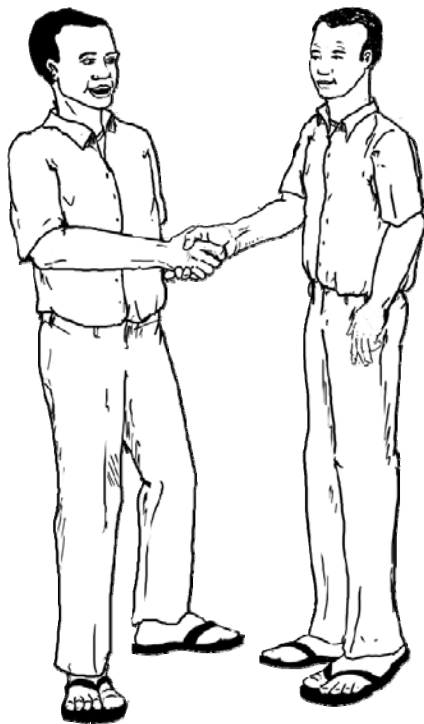

"Cursed? That can't be, Phicol - that well has been a blessing from God to your entire village! We must reason together and find the source of this problem. Let's finish watering our animals and take them to the pasture to graze. Then we can go to your village and find out what is wrong with the water." So they went off together to the pasture.

Along the way, Phicol told Abimelech that the water coming from the pump was no longer clear. It tasted dirty and was worse after it rained. When they arrived at Phicol's village, they inspected the pump and the area around it. "What do you think, Abimelech?" asked Phicol.

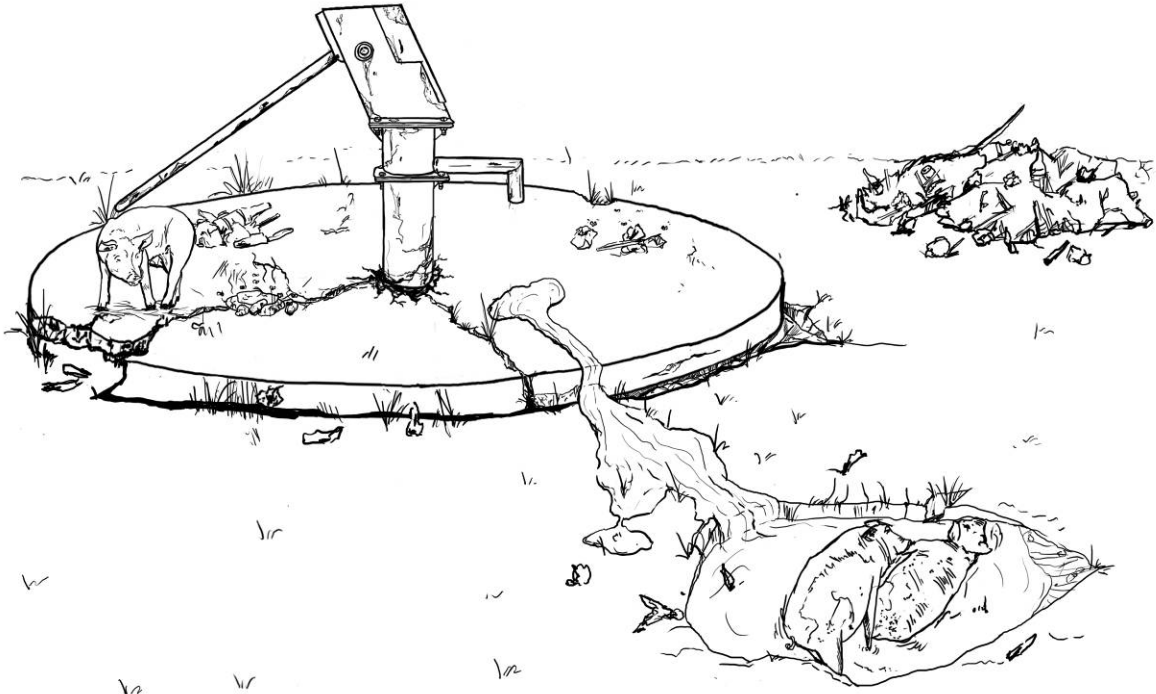

**Figure 31 Damaged Well**

In your teams, study the drawing of the damaged well and list all of the problems that you see which might lead to the villagers becoming sick. Share your observations with the class.

---

---

---

---

***We return to our story...***

As Abimelech pointed out all of these problems with the pump, its pad, and the surrounding area, Phicol was surprised. “I didn’t realize those things could hurt the quality of our water!” Phicol said with amazement. “How can we fix it? ... No, wait,” Phicol said after thinking a minute, “We don’t have much money to spend on this. What do we need to do first?”

- How would you advise Phicol? Working with your team, list in order of importance the corrections they should make:

---

---

---

**Getting back to our story...**

A little while later, after the elders of Phicol’s village had agreed on the work to be done and had gathered the necessary materials, Abimelech was helping Phicol work on the well. Phicol asked him, “Why did these problems happen to our well? I don’t see the same things going wrong with your well.”

“We have a village Water Committee” answered Abimelech “and they make sure that the pump and the area around it stays clean and in good condition.” “What do they do?” asked Phicol.

Working with your team, list the things that a Village Water Committee should do regularly to keep a well and pump in good condition:

---

---

---

---

**Returning to Phicol and Abimelech ...**

“Those are great ideas!” exclaimed Phicol, “But how do you choose who will be on the Water Committee and how do you pay for all that work?”

Abimelech replied, “When we first got our well we decided to elect Water Committee members that represent the different groups in the village; men, women, farmers, herdsman, and so on. Every month each family contributes a small amount of money depending on family size. The Water Committee makes a full report to the village leaders every three months so there is no question that the money is being properly used to keep the well in good condition. But your village might prefer a different approach. I heard of a village where the well was owned by one person and everyone purchased water from him. If that pump stops working the owner can’t earn any money so he works hard to keep it in good condition. What matters is that somebody has to take responsibility for your well or it will just fall apart and children will once again get sick.”

After thinking about that last statement Phicol said, “You speak the truth, Abimelech. That is why I like you. I’m going to bring this up at our next village meeting.”



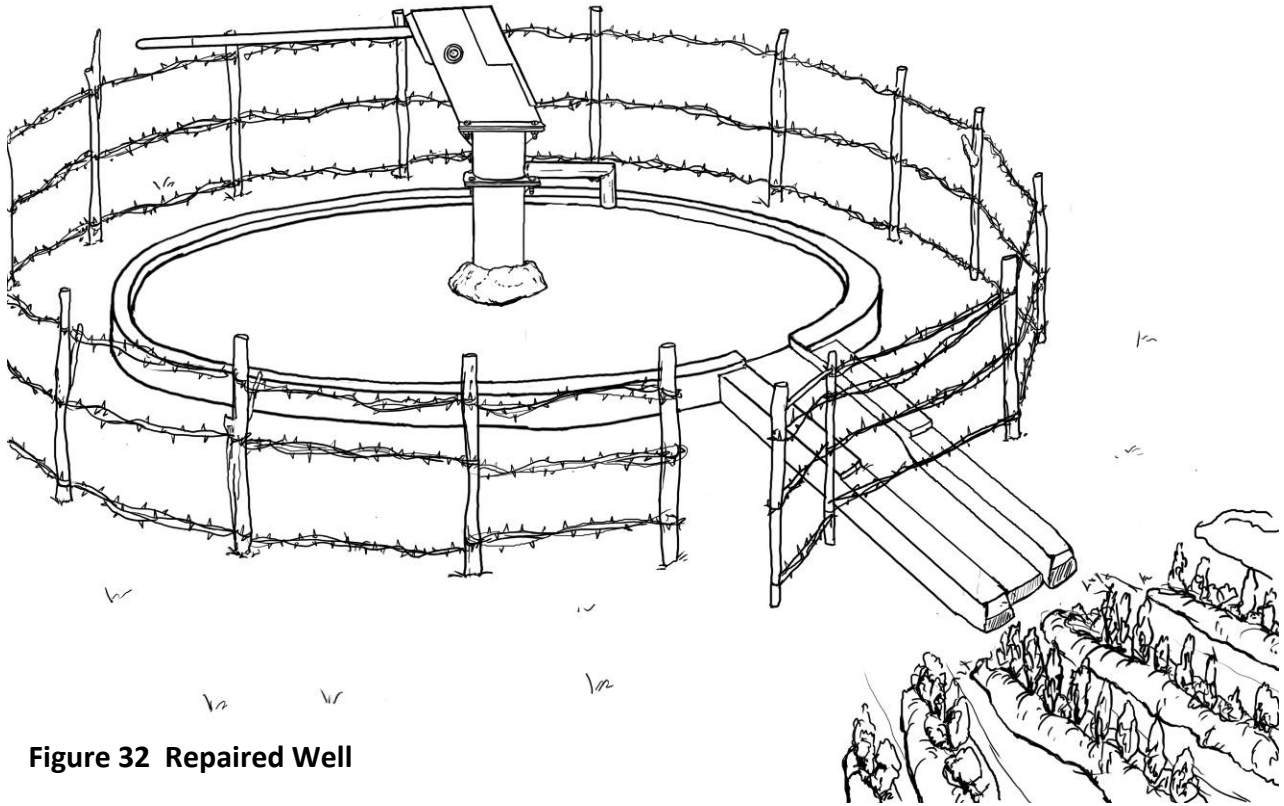

**Figure 32 Repaired Well**

Working with your team, examine this drawing of an improved well and pump area. List any improvements that your team did not consider before.

---

---

---

---

**2. Use Concrete to Restore a Pump Pad - 60 minutes**

Concrete is made from cement, sand, gravel and water.

- For a pump pad, these ingredients are commonly combined in a 1:2:4 ratio to achieve maximum strength - 1 part cement, 2 parts sand, 4 parts gravel. If not enough cement is used, then the result is called “sandcrete” and it will eventually fall apart.
- When filling cracks in a pump pad, the gravel may be left out of the mix so the concrete can get into the smallest spaces. Use 1 part cement and 2 parts clean sand.
- When patching existing concrete brush on a bonding agent made of a 50:50 mix of white glue and water. This will help the new concrete adhere strongly to the old.
- The amount of water used to mix the ingredients is the most important factor in determining the final strength of the concrete. Use the least amount of water that will still give a workable mix.
- It is also very important to use clean sand and gravel. Even small amounts of silt, clay or bits of organic matter will weaken the concrete.
- If there are several grades of cement available, always use the best grade. Cheap cement does not hold up to heavy use so it is not a bargain in the long run.

It takes time for concrete to cure. After a week concrete has gained most of its strength but it takes about a month to cure to full strength.

There are three basic steps to patching concrete:

**Step 1. Prepare the damaged section**

- Remove any broken or crumbling concrete.
- Chisel large cracks to clean them out.
- If the pad has been undercut dig out any loose dirt.
- Clean the surfaces of the existing pad with water and a wire brush.
- Use boards or rocks to form an edge for the new concrete.
- Add reinforcing steel or wire mesh to strengthen large repair sections.

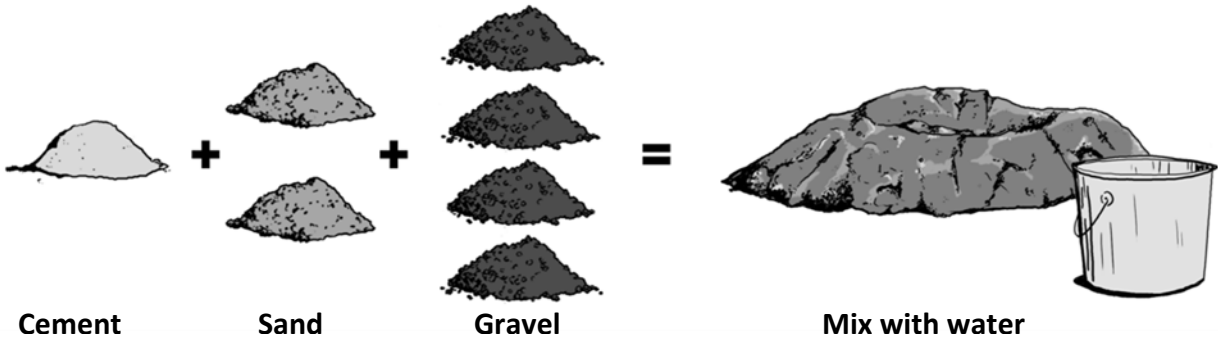

**Figure 33 Mixing Concrete**

### Step 2. Mix and apply the new concrete

- Mix the dry components - 1 part cement, 2 parts sand, 4 parts gravel.
- Add water slowly, constantly mixing until all parts are damp but not runny.
- Wet the surfaces of existing concrete with a bonding agent.
- Apply the new concrete.
- Smooth the new surface with a moist “float” or trowel.

### Step 3. Cure the concrete

- Moisten and smooth the surface as it begins to appear dry.
- Cover with straw, plastic sheet, or cloth and sprinkle with water.
- Moisten and re-cover daily for 5 days.

**Note:** The 1:2:4 ratio of cement:sand:gravel recommended for a pump pad assumes good quality cement is being used. More cement might be required if the quality is doubtful. When constructing a latrine slab, a ratio of 1:2:3 cement:sand:gravel is recommended because a higher strength is required.

### Exercise

Practice with your team patching a piece of concrete.

*Notes:*

---

---

---

---



## Lesson 5.2 Clearing an Obstructed Well



### Purpose

*Identify problems with a well that are not the result of mechanical failure of the pump.*



### Objectives

*By the end of this lesson, participants will have*

- Considered why a well might not yield much water, or none at all, due to problems other than hand pump malfunction.
- Constructed a bailer and used it to practice removing silt and rocks from a well.



### Materials

- Markers and Flipcharts for each group.
- Posters of Silted Casing, Rocks in the Casing, and Collapsed Casing.
- Bailer and rope.
- Optional bailer construction exercise: 3-inch PVC, PVC cement, rubber flap, pliers, heavy wire, screws, screwdriver, hacksaw.
- Well cleanout tool.
- Bucket of silt and/or light sand.
- Bucket of rocks 2-6 cm in diameter.
- Mock well for each team – 4” PVC casing with a bottom cap and lashed to the side of a pickup truck.



### Preparation

- The “Case Studies” can be assigned as homework with presentations being conducted at the start of the next day.
- Prepare the pieces of the bailer in advance for quick construction.
- The lengths of PVC should be set up so they can be reached from the top, as if they were a well casing. Tying them to the bed of a pickup truck works well.



### Time

105 minutes



### Steps

1. Introduction.
2. Case Studies on Obstructed Wells.
3. Use a Bailer to Remove Silt
4. Remove Rocks with a Well Cleanout Tool

*This lesson is designed as an opportunity for the students to gain training experience. If it is used that way, allow adequate preparation time during class; assigning homework is rarely successful. Otherwise, handle it as a facilitator presentation followed by a Q&A session.*



### 1. Case Studies on Obstructed Wells - 30 minutes

What does it mean when you are called back to replace the piston seals on a pump after a very short time, because sand gets into the well? Some pump failures are not the “fault” of the

pump, but occur because the well was poorly constructed. This lesson identifies well-related problems that a pump repair technician may encounter. It is important to be able to identify and fix – if possible – problems with well construction.

Each team will be assigned one of the pump repair problems described below. Study and discuss it among your team. Be prepared to make a summary presentation to the rest of the class describing the problem and the actions needed to correct it.

### Case Study 1: Silted Casing

If there is no gravel pack or if it has large gaps, then silt and fine sand can get through the well screen into the well casing. The well is said to be “pumping sand.” If this is happening slowly so that the silt builds up gradually, then it is possible to extend the life of the well.

#### Symptoms:

- Silt or fine sand in the pump discharge.
- Piston seals wear out quickly.
- The pump piston will not move.
- There is no water in the well, but other wells nearby show the water table has not dropped.

#### Investigation:

1. Remove the riser main and pump cylinder. If the pump cylinder is stuck, then adding water to the well and shaking the riser main while turning it to the right might free it. (Don't turn to the left because that will unscrew it.) If the pump cannot be removed, then there is not much that can be done except to recover as much of the riser main and pump rod as possible and then abandon the well (see the Well Abandonment lesson).
2. Measure the depth to the bottom of the well and compare it with the recorded original well depth. There should normally be a meter or more between the bottom of the pump and the bottom of the well.
3. Probe the bottom of the well with a weight on a string. Does it feel “soft” (indicating silt or sand) or “hard” (indicating the well bottom or rocks)?

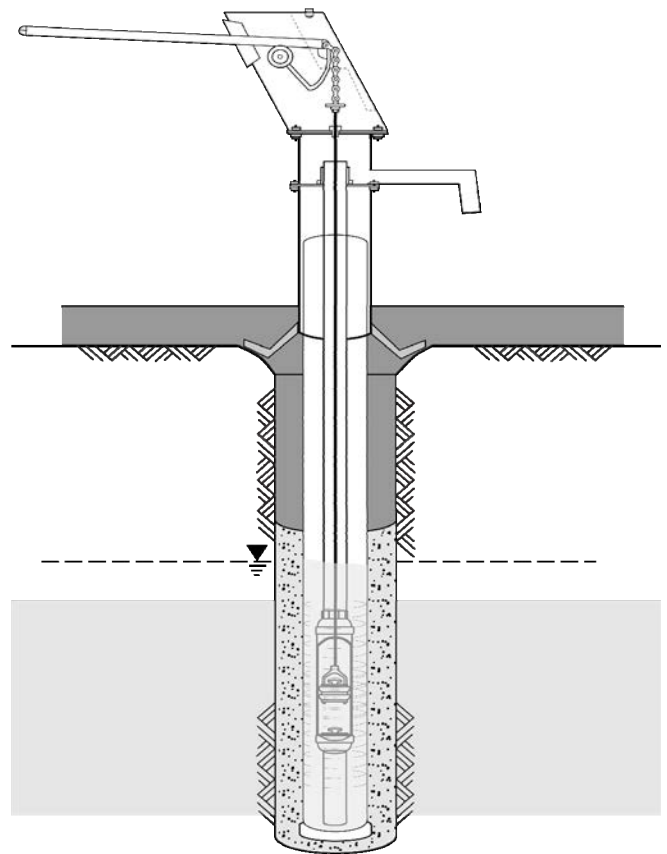

Figure 34 Silted Casing

**Correction:**

1. Add water to the well so that there is at least two meters of water above the silt layer.
2. Agitate the silt with a bailer then pull the bailer up when it is full. The water poured out of the bailer should have sand or silt in it. Repeat the process until the hard bottom of the well casing can be felt and the water becomes clear.
3. If an air compressor is available, then using an air-lift pump may be quicker than cleaning out a well with a bailer. An air-lift pump consists of a discharge pipe, usually 1-inch (24 mm) diameter PVC, and a 1/4-inch (6 mm) or 3/8-inch (10 mm) flexible hose air line. The air line is attached about a foot (300 mm) above the open bottom of the discharge pipe using a fitting that angles the air flow up the pipe. As compressed air rises up the discharge pipe it causes a strong suction that lifts water, sand, and even small stones. For this type of pump to work the water level in the well must be quite high so it may be necessary to keep adding water to the well.
4. Periodically measure the well to see if it is getting deeper. If it is not, then sand or silt could be flowing into the well as fast as it is being removed. This would indicate a collapsed or broken casing.
5. Before reinstalling the pump, add a slotted tail pipe to the bottom of the pump cylinder. The tail pipe should be as long as the well depth permits and capped at the bottom. Wrap the tail pipe with several layers of woven plastic sack material (typically used for rice sacks) to filter out silt and fine sand that may come back into the well.

**Case Study 2: Rocks in the Casing**

If the borehole is not sealed when a pump is removed from a well, then children (or even adults) may drop rocks down the borehole. It makes a very interesting sound, so they might drop rocks until the well is completely filled.

**Symptoms:**

- Rocks can be seen by using a mirror to reflect sunlight into the casing.
- There is no water in the well, but other wells nearby show the water table has not dropped.

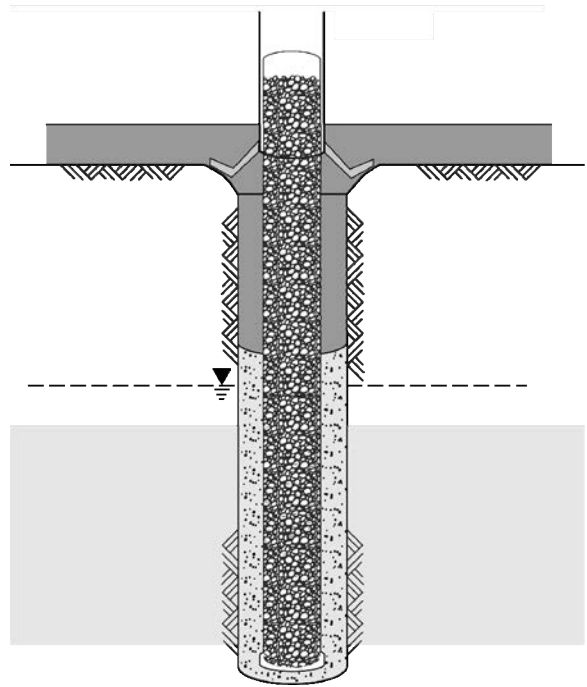

**Figure 35 Rocks in Casing**

**Investigation:**

1. Measure the depth to the bottom of the well and compare it with the recorded original well depth.
2. Probe the bottom of the well with a weighted string. Does it feel “soft” (indicating silt or sand) or “hard” (indicating the well bottom or rocks)?

**Correction:**

1. Removing rocks from a well is a fishing exercise and the same principles apply as when a tool is dropped in a well. The size of rocks in the well can be estimated by looking at rocks on the ground around the well.
2. Lifewater has developed a well cleanout tool that can be used to remove rocks from a well. Instructions for making this tool are included in the Appendix.

**Case Study 3: Collapsed Casing**

A well casing made of weak PVC may break or collapse inward from the pressure of the soil and water against it.

**Symptoms:**

- Coarse sand, larger than the well screen slots, is in the pump discharge.
- The pump piston will not move.
- There is no water in the well, but other wells nearby show the water table has not dropped.

**Investigation**

1. Begin as you would with a silted casing, removing the pump (if possible) and comparing the depth of the well with its original depth. If the pump can't be removed, recover as much of the riser main as possible and abandon the well.

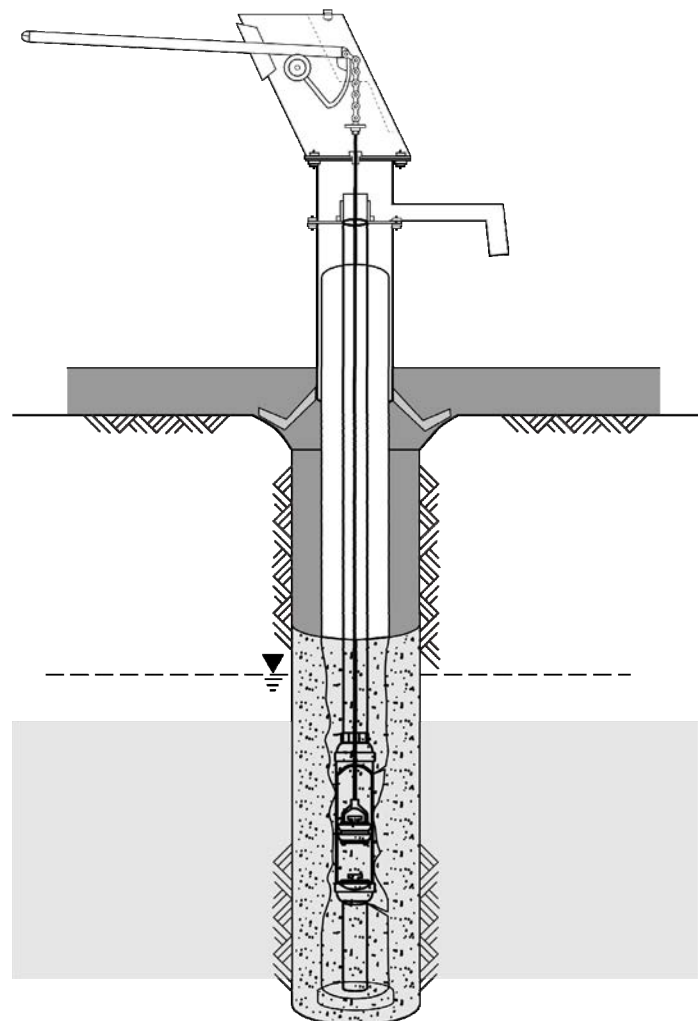

**Figure 36 Collapsed Casing**



2. If the pump can be removed, inspect the casing to see how much damage there is. In a shallow well, use a mirror to reflect sunlight into the casing.
3. If the well is too deep to see the damaged section, an inspection tool can be made using lengths of 1-inch PVC. Firmly attach a nail to the bottom of the 1-inch PVC so that it sticks out at a right angle. The slots in the well screen can be felt by running this nail up and down the casing. With practice, a break in the casing or well screen can be detected. It is important to determine how badly the old casing is damaged. Is the well screen just broken in a few places so that sand can flow in? Or is it collapsed so much that the inspection tool can't reach the bottom of the well?

**Correction:**

1. Clean out as much silt and sand as possible and insert a smaller diameter casing inside the collapsed casing. The new casing must be large enough to fit a pump cylinder, so if the original casing is 4-inch PVC, then the replacement casing would have to be 3-inch, which does not give much clearance for the pump cylinder (none for an Afridev cylinder). Depending on the static water level, it may be possible to use a longer tail pipe to get past the collapsed section.
2. Leave the bottom open on the replacement casing so sand and silt can be bailed out as the new screen and casing is lowered into the well. If the old casing is so badly collapsed that new casing (or a tail pipe) can't move past it far enough below the static water level, then the well must be abandoned (see the Well Abandonment lesson).
3. Once the new casing is in place, seal off the bottom by dropping a small plastic sack filled with about 1 liter of wet cement into the well. This will prevent silt and sand from flowing up into the new casing through the bottom.

**Case Study 4: Iron Bacteria**

If the water in a well contains high levels of dissolved iron or manganese then "iron bacteria" can invade the well. They do not cause disease, but iron bacteria make the water unpleasant to drink or use.

**Symptoms:**

- A thick brown or rust-colored slime on the pump parts and well casing.
- The water has a bad taste or odor.
- Well yield is reduced.



**Correction:**

1. If there are iron pipes or fittings in the well, replace them with galvanized, stainless steel, or PVC.
2. Carefully disinfect all of the pump components then shock-chlorinate the well as described in the Well Disinfection lesson. Repeated surging of the well can loosen the slime that iron bacteria will form.
3. Since iron bacteria occur naturally in the groundwater, chlorination might be needed on a regular basis to keep them from building up.

**2. Use a Bailer to Remove Silt - 30 minutes**

*As an option if time allows, each team can make a bailer following the instructions in the Appendix and then use that bailer to remove silt from a practice well.*

**Bailers**

A “bailer” is a length of PVC pipe, usually about a meter long, with a diameter that easily fits into the well casing. It is used to “develop” the well by removing silt and sand that remains after the well is drilled or that may have accumulated in the well over time. The bailer is typically raised and lowered using a tripod and pulley. The motion of the bailer as it moves up and down under water creates a “surge” through the well screen that helps to improve well yield.

At the bottom of the bailer is a one-way valve and at the top is an attachment point for a rope. As the bailer is lowered into the well, the one-way valve allows it to fill with water. When the bailer is raised, the valve holds the water. The bailer is brought to the surface and tipped upside down to empty it.

Bailers can be purchased from drilling supply companies, but they are relatively easy to make. There are several different ways to make the one-way valve. One example is described in Appendix 5.

In your teams, use a bailer to practice removing silt from a practice well.

**3. Remove Rocks with a Well Cleanout Tool - 30 minutes**

Examine the Well Cleanout Tool you have been given as the Facilitator explains its operation. We will then use it to remove rocks from a practice well.

Lower the tool until it rests on the rocks and then take two or three strong pulls. Bring the tool out and turn it upside down to empty it.

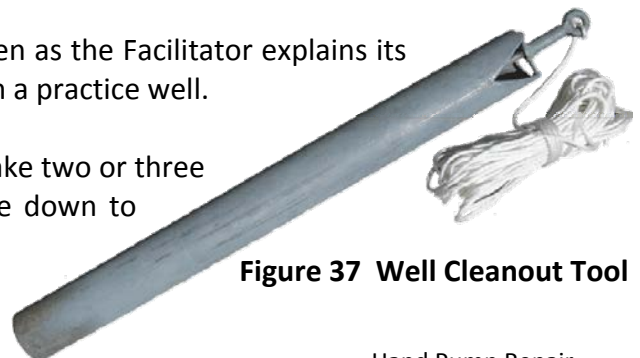

**Figure 37 Well Cleanout Tool**



## Lesson 5.3 Well Closure



### Purpose

*Examine the reasons for closing a well and the proper way to do it.*



### Objectives

*By the end of this lesson, participants will have*

- Considered ways an unused well can be a problem and examine methods to properly close a well.



### Materials

- Flipchart and markers



### Preparation

- Study lesson ahead of time.



### Time

30 minutes



### Steps

1. Ways to Properly Close a Well.
2. Risks of an Improperly Abandoned Well.



### 1. Ways to Properly Close a Well - 15 minutes

When an obstructed well cannot be cleared and put back into productive service, then it must be properly closed.

In your teams, study these well closure methods and be prepared to discuss them with the rest of the class.

1. Break up and remove the pump pad.
2. If there is a good sanitary seal around the casing, then cut off the casing at the top of the sanitary seal. Fill the casing with clean sand or rock to within about 2 meters from the top. Fill the remainder of the casing with cement. Backfill any low spots with soil.
3. If there is no sanitary seal around the casing, then dig a hole around the casing about 1 meter deep and about a half meter in diameter. Cut off the casing above the bottom of the hole. Fill the casing with clean sand or rock to within about 2 meters from the top. Fill the remainder of the casing and two-thirds of the hole with cement. After the cement sets, backfill the hole with soil.
4. If there is a well construction report available for this well, then add to it a note providing the date and reason the well was abandoned and the procedure used to seal it.

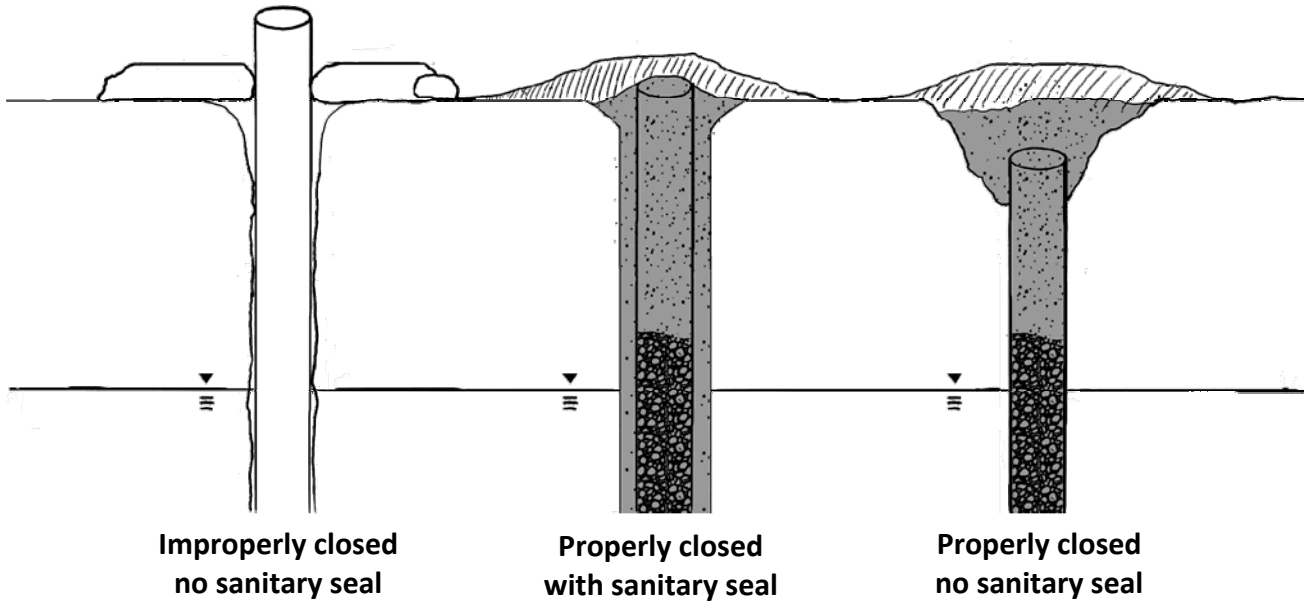

**Figure 38 Well Closure**

 **2. Risks of an Improperly Closed Well - 15 minutes**

In your teams, discuss and make a list of the problems that could be caused by a well that is left open.

---



---



---



---

➤ What is the most important thing to do when closing a well?

---



---

➤ We have been discussing boreholes. How might you close a hand-dug well?

---



---

➤ What would you say to a Water Committee to explain why a well needs to be closed?

---



---



---



---

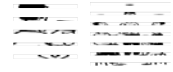

## Lesson 5.4 Upgrading a Hand-Dug Well



### Purpose

*Identify ways to upgrade a hand-dug well.*



### Objectives

*By the end of this lesson, participants will have*

- Examined ways to improve an open, hand-dug well.



### Materials

- Flipchart and markers for each team
- Poster of before & after hand dug well



### Preparation

- Study lesson ahead of time.



### Time

45 minutes



### Steps

1. Disadvantages of a Hand-dug Well
2. Upgrading a Hand-dug Well
3. Alternative Solutions



### 1. Disadvantages of a Hand -dug Well - 5 minutes

In many parts of the world, hand-dug wells are much more common than drilled wells (boreholes). This is because it does not take special machinery to dig a well and a bucket on a rope costs very little compared to a hand pump. So if people can dig to the groundwater, it may be possible for every family to have their own well.



The main **advantage** of a hand-dug well is its low cost. But there are major **disadvantages** compared to a drilled well:

- A hand-dug well is easily contaminated by surface water.
- A hand-dug well is easily contaminated by dirt picked up by the bucket and rope.
- A hand-dug well usually cannot extend very far below the water table so in times of drought it will go dry sooner than a drilled well.
- A hand-dug well tends to have very limited yield.
- A hand-dug well is very dangerous to construct and may collapse if not adequately reinforced.
- Children and animals can fall into a hand-dug well.

**2. Upgrading a Hand-dug Well - 25 minutes**

In your teams, review the “Proper Well Construction” lesson. Pay close attention to the improvements that keep surface water from entering the well.

Discuss among yourselves how you could modify an existing hand dug well to keep surface water from contaminating it. Using the outline below labeled “After Upgrade,” make a drawing that represents your improvements. Be ready to share your ideas with the class. If you have experience with this type of work, include a rough estimate of what you think it would cost.

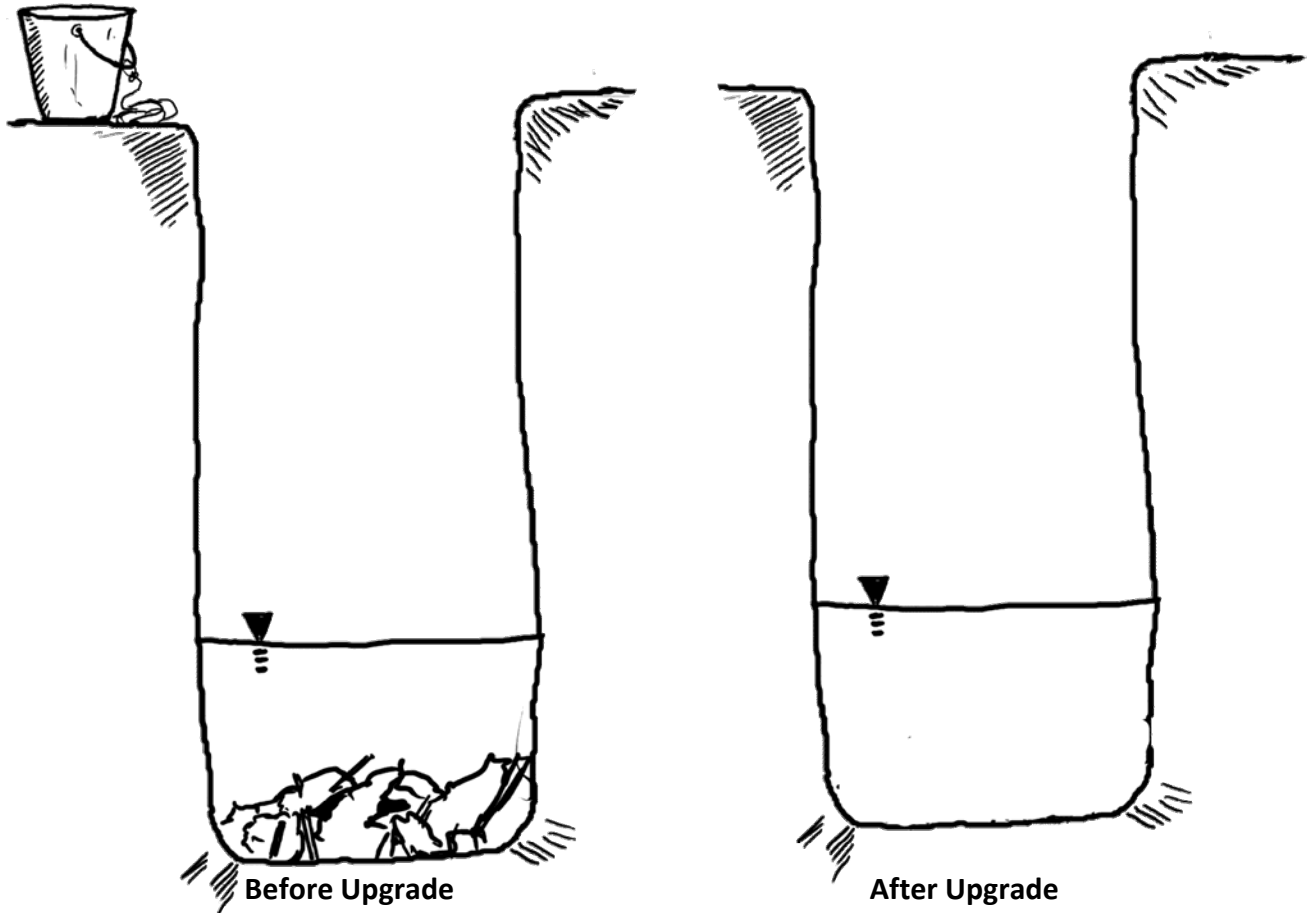

Figure 39 Hand-dug Well

**3. Alternative Solutions - 15 minutes**







➤ If it would be too expensive to upgrade every hand-dug well in a community, what alternatives might there be for providing safe drinking water?

---

---



## Lesson 6.1 Roles and Attitudes

	<b>Purpose</b> <i>To share ideas on the many roles an effective pump repair technician has.</i>
	<b>Objectives</b> <i>By the end of this lesson, participants will have</i> <ul style="list-style-type: none"> <li>• Considered the different roles and attitudes that a community development worker can play.</li> </ul>
	<b>Materials</b> <ul style="list-style-type: none"> <li>• None</li> </ul>
	<b>Preparation</b> <ul style="list-style-type: none"> <li>• Study lesson ahead of time.</li> </ul>
	<b>Time</b> 30 minutes
	<b>Steps</b> <ol style="list-style-type: none"> <li>1. Pump Repair Roles</li> <li>2. Godly Pump Repair Ethics</li> </ol>

### 1. Pump Repair Roles – 20 minutes

Get into groups of two or three; you will be assigned several words. **Discuss** among yourselves the following question. Then select a representative of your group to report what you decided to the rest of the class.

➤ **In what ways do you think these words apply to pump repair?**

**Diplomat** - \_\_\_\_\_  
 \_\_\_\_\_  
 \_\_\_\_\_

**Detective** - \_\_\_\_\_  
 \_\_\_\_\_  
 \_\_\_\_\_

**Repairman** - \_\_\_\_\_  
 \_\_\_\_\_  
 \_\_\_\_\_

**Doctor** - \_\_\_\_\_

\_\_\_\_\_

\_\_\_\_\_

**Disciple** - \_\_\_\_\_

\_\_\_\_\_

\_\_\_\_\_

**Trainer** - \_\_\_\_\_

\_\_\_\_\_

\_\_\_\_\_

**Evangelist** - \_\_\_\_\_

\_\_\_\_\_

\_\_\_\_\_

**Businessman** - \_\_\_\_\_

\_\_\_\_\_

\_\_\_\_\_

**Friend** - \_\_\_\_\_

\_\_\_\_\_

\_\_\_\_\_



## **2. Godly Pump Repair Ethics – 10 minutes**

Pump repair, like any other work, involves handling money and items of value such as tools or pump parts. As representatives of Jesus Christ, we must be trustworthy and walk in the highest integrity. We all know that the world is corrupt, but with God's help we do not need to be corrupt ourselves.

It has been reported that some pump repair technicians have cheated their customers by charging them for a new part, but putting in an old one instead. Or they have cheated their employers by selling tools or parts, keeping the money, and reporting that the tool was stolen or the part installed in a well. May such dishonest ways never be found among you!

- If you find that a co-worker is being dishonest, what should you do about it?



## Lesson 6.2 Encouraging Village Water Committees



### Purpose

*Develop and rehearse ways to help a Village Water Committee do a better job.*



### Objectives

*By the end of this lesson, participants will have*

- Explored ways to keep a pump working by encouraging the community to take ownership of their well and responsibility for its routine maintenance.



### Materials

- None



### Preparation

- Study lesson ahead of time.



### Time

90 minutes



### Steps

1. Keeping the Pump Working
2. Village Water Committees
3. Pump and Well Maintenance
4. Encouraging a Village Water Committee



### 1. Keeping the Pump Working - 10 minutes

In your teams, read and discuss the following paragraphs.



**Figure 40 Village Market**

Every community has resources that are available to the people year after year. These resources include environmental conditions (air, water, soil), human inventions (roads, electricity, machines), and social institutions (churches, schools, markets, festivals).

In most cases, what keeps these resources available for the community is a commitment by the community to take responsibility for them. For example, the entire community benefits from a weekly market so the community members (sellers and buyers) work together to keep it going. Even resources for which the government has the main responsibility, taxes or fees collected from the community makes its work possible.



List examples of resources (environmental, human, or social) that are found in your community and that are sustained by the efforts of the community.

---



---



---

 **2. Village Water Committees – 10 minutes**

Experience has shown that a Village Water Committee (or Water and Sanitation Committee) is the most effective way to keep a hand pump operating for the benefit of the community.



**Figure 41 Water Committee**

➤ In your area, what responsibilities do Village Water (and Sanitation) Committees have?

---



---



---



---



---



---



---



---

*This can be done as a three-pile sorting exercise*



Here are some characteristics of an effective Village Water Committee:

- It includes representatives of various groups in the village, especially women.
- It takes a lead in identifying the community's water and sanitation problems.
- It helps educate the community on water, sanitation, and hygiene issues.
- It promotes water, sanitation, and hygiene projects in the community.
- It takes responsibility for operating and maintaining water and sanitation systems and for collecting and managing the money needed for this work.
- It establishes rules (such as fees and hours of operation) for the water pump.
- It resolves disputes over the community's water and sanitation systems.

➤ What characteristics on this list are not true for Water Committees in your area?

---

---



### **3. Pump and Well Maintenance - 25 minutes**

No matter what type of pump a community has, there are some maintenance and repair operations that will be easy for them to do and some that will be hard for them.

➤ What are some things that can go wrong with a hand pump and well area that may be prevented (or delayed) by simple, routine maintenance that most communities could do themselves?

---

---

---

---

➤ What are some things that can go wrong with a hand pump or the area around the well that probably require training or special tools?

---

---

---

 **4. Encouraging a Village Water Committee - 45 minutes**

In your work as a pump repair technician, you have encountered the following situation:



A community in the area where you are working has a Water Committee, but they are not doing many of the things that we decided were helpful for a Water Committee to be doing. The evidence for this is obvious: their pump has been broken for a long time, the pad is cracked from neglect, they have collected no money for repairs, and they are blaming each other for the problems.

Your assignment is to help this Water Committee understand their role and do a better job at it. In the culture where this committee lives, to lecture them as an “expert” would be highly offensive and they would not listen. Therefore, important messages like this are communicated through song, dance, or drama.

Working with your team, develop a song, dance, or drama that will help this Water Committee understand their role. You will make your presentation to the rest of the class as if we were that Water Committee. If you think more than one session with the committee is needed, then just make your first presentation and then explain what else you would do.

➤ What would you do differently if the community did not have a Water Committee?

---

---

---

---

---

---



## Lesson 6.3 Hygiene and Sanitation



### Purpose

To introduce healthy hygiene and sanitation behaviors.



### Objectives

By the end of this lesson, participants will have

- Reviewed common disease pathways
- Examined disease-blocking practices



### Materials

- Markers and flip chart



### Preparation

- Study lesson ahead of time



### Time

60 minutes



### Steps

1. Diarrheal Disease
2. Handwashing
3. Keeping Water Safe
4. Safe Fecal Disposal
5. Your Role



### 1. Diarrheal Disease - 10 minutes

One of the most common health problems in a rural community, especially among children, is diarrhea. The dehydration that results from diarrhea can lead to death in a very short period of time. The germs that cause diarrhea are transmitted through contact with feces. We get sick when those feces get into our mouth. There are many ways this can happen; contaminated water, soiled hands, and flies are common pathways. Figure 42 shows some of these pathways.

Safe water is one way to reduce the spread of diarrheal disease. Good hygiene and sanitation practices are also necessary to better block all the pathways for disease transmission; not only for diarrhea, but for many other diseases as well.

It takes education - and time - for a community to recognize behaviors that increase the risk of getting sick and to begin changing those behaviors. For this reason, Lifewater has developed a full training program aimed at promoting good hygiene and sanitation practices. These training manuals include; "WASH Promotion," "Handwashing at Critical Times," "Keeping Water Safe," "Safe Fecal Disposal," "Sanitation: Latrine Design and Construction," and "WASH in Schools." This lesson provides a summary overview of some of the key principles covered in these manuals.

It is possible to reduce disease in a community by blocking these disease transmission pathways by washing hands, covering food, avoiding open defecation, protecting water from fecal contamination, and many other simple practices.

Therefore, in addition to drilling wells, an effective water development program will also teach the community good hygiene and sanitation practices. Without these, safe water can easily become contaminated and the benefits of safe water will be greatly reduced.

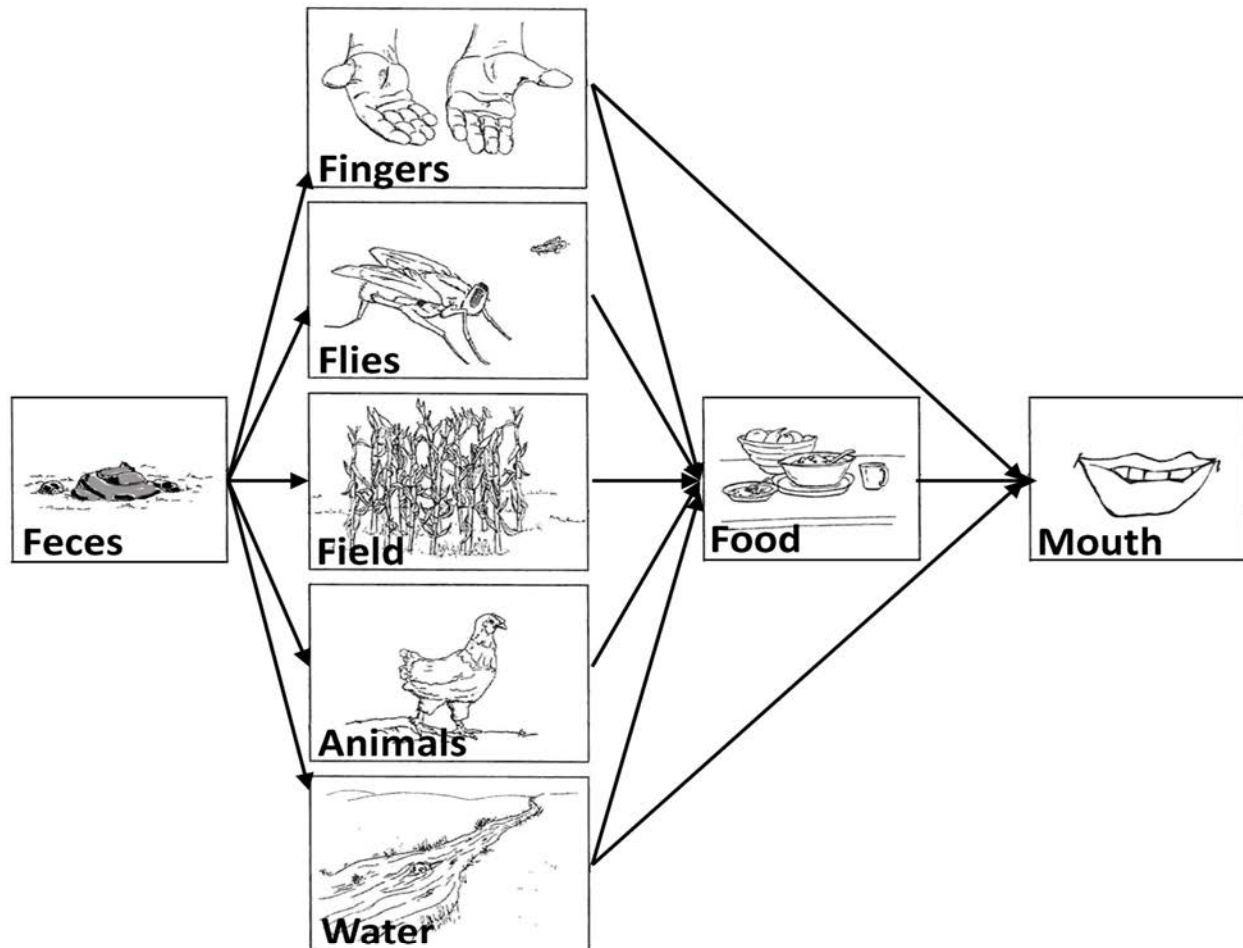

**Figure 42 Diarrhea Transmission Pathways**

 **2. Handwashing - 10 minutes**

Washing our hands is the first line of defense against disease. There are two times when it is critical that we wash our hands:

- AFTER contact with feces.
- BEFORE handling food.

There are many ways to wash our hands, but the most effective is with soap and water. A very simple device for this can be made using a plastic jug. It's called a Tippy-Tap and is illustrated in Figure 43. Put up a Tippy-Tap by the latrine and near where food is prepared and eaten to remind people to wash their hands.



**Figure 43 Tippy-Tap**

### **3. Keeping water safe - 10 minutes**

As pump repair technicians, you are in the community to restore a safe source of water. All of the well construction and maintenance procedures – especially installing a deep sanitary seal, building a strong pump pad, and disinfecting the well – are designed to keep the groundwater from becoming contaminated. But what if people carry their water in a dirty bucket? Or leave the bucket uncovered at home?

Some simple practices for keeping water safe include:

- Wash the water bucket with soap and water.
- The bucket used to collect water is only used for that purpose.
- Keep the water bucket covered.

- Avoid touching water in the water bucket; dip it out with a clean cup.
- If using a hand-dug well, cover the well and install a hand pump.
- Protect water sources from feces by burying feces or using a latrine
- Use fences to keep animals away from safe water sources.

 **4. Safe Fecal Disposal - 15 minutes**

The proper disposal of feces is probably the most important thing that a community can do to promote good health. This is so important, that God has commanded it!

 **Deuteronomy 23:12-14**  
Designate a place outside the camp where you can go to relieve yourself. As part of your equipment have something to dig with, and when you relieve yourself, dig a hole and cover up your excrement. For the LORD your God moves about in your camp to protect you and to deliver your enemies to you. Your camp must be holy, so that he will not see among you anything indecent and turn away from you.

This command was given to the Hebrews as they were travelling from Egypt to Canaan. It was given to promote their health, so it is equally important to us today. It might take time for a community to gather the resources to build a latrine. But if they are now practicing open defecation, then simply digging a small hole and covering their feces is something very simple that can be done. And the benefits will be great.

 **5. Your role - 15 minutes**

As pump repair technicians, you may not have many opportunities to instruct the community in good hygiene and sanitation practices. But you can be a good example.

- In what ways can a pump repair team model good hygiene and sanitation behavior?

---

---







---

---

---



## Lesson 6.4 Safety Devotion and Daily Briefing

	<b>Purpose</b> <i>Develop a habit of watching for – and correcting - safety problems.</i>
	<b>Objectives</b> <i>By the end of this lesson, participants will have</i> <ul style="list-style-type: none"> <li>• Related a scriptural passage to safety concerns.</li> <li>• Reviewed safety considerations for each day’s activities.</li> </ul>
	<b>Materials</b> <ul style="list-style-type: none"> <li>• None</li> </ul>
	<b>Preparation</b> <ul style="list-style-type: none"> <li>• Review upcoming activities to warn of safety hazards.</li> <li>• Observe and make note of any unsafe conditions to mention in next briefing.</li> </ul>
	<b>Time</b> 15 minutes (each morning)
	<b>Steps</b> <ol style="list-style-type: none"> <li>1. Look to Each Others’ Interests</li> <li>2. Daily Safety Briefing</li> </ol>

 **1. Day 1 - Look to Each Others’ Interests - 10 minutes**

 Each of you should look not only to your own interests, but also to the interests of others.

Philippians 2:4 NIV

Discuss among your team how this passage relates to maintaining safety during pump repair. List below all of the ways you can think of to “look to the interests of others” then be prepared to share your thoughts with the rest of the class.

---



---



---



---



---





## 2. Daily Safety Briefing - 15 minutes

Use the spaces provided to take notes on each day's safety briefing. If you do not write it down, you will more likely forget it – and somebody could get hurt as a result.

### Day 1:

#### Safety hazards to watch for today:



Head injuries can easily happen when working on a pump, so ALWAYS wear a hard hat! Please do not let something like this happen to you or to your team mates.

Also wear gloves. There are many opportunities for a pinched finger and wrenches raise burrs on the pipe which can cut deeply.

**Figure 44 Head Injury**

It is important to have a simple first aid kit with your tools. The Facilitator will point out the location of the first aid kit for this class.

### Day 2:

---

#### Unsafe conditions or actions observed yesterday:

#### Safety hazards to watch for today:

### Day 3:

---

#### Unsafe conditions or actions observed yesterday:

#### Safety hazards to watch for today:

### Day 4:

---

#### Unsafe conditions or actions observed yesterday:

#### Safety hazards to watch for today:

**Day 5:**

---

**Unsafe conditions or actions observed yesterday:**

**Safety hazards to watch for today:**

**Day 6:**

---

**Unsafe conditions or actions observed yesterday:**

**Safety hazards to watch for today:**

**Day 7:**

---

**Unsafe conditions or actions observed yesterday:**

**Safety hazards to watch for today:**

**Day 8:**

---

**Unsafe conditions or actions observed yesterday:**

**Safety hazards to watch for today:**

**Day 9:**

---

**Unsafe conditions or actions observed yesterday:**

**Safety hazards to watch for today:**

**Day 10:**

---

**Unsafe conditions or actions observed yesterday:**

**Safety hazards to watch for today:**

**Day 11:**

---

**Unsafe conditions or actions observed yesterday:**

**Safety hazards to watch for today:**

**Day 12:**

---

**Unsafe conditions or actions observed yesterday:**

**Safety hazards to watch for today:**



## Lesson 6.5 Daily Devotions



### Purpose

*Share insights into God's Word with one another.*



### Objectives

*By the end of this lesson, participants will have*

- Led the class in a brief devotion from the Bible.



### Materials

- Bible



### Preparation

- The first day's devotion (safety) will be led by the facilitator.
- Ask students to volunteer to lead devotions on the following days.



### Time

15 minutes



### Steps

1. Scripture for the Day



**Day 2 – Scripture for the Day - 15 minutes      Team:**

**Leader:**

**Bible verses:**

**Notes:**



**Day 3 – Scripture for the Day - 15 minutes      Team:**

**Leader:**

**Bible verses:**

**Notes:**



**Day 4 – Scripture for the Day - 15 minutes**

**Team:**

**Leader:**

**Bible verses:**

**Notes:**



**Day 5 – Scripture for the Day - 15 minutes**

**Team:**

**Leader:**

**Bible verses:**

**Notes:**



**Day 6 – Scripture for the Day - 15 minutes**

**Team:**

**Leader:**

**Bible verses:**

**Notes:**



**Day 7 – Scripture for the Day - 15 minutes**

**Team:**

**Leader:**

**Bible verses:**

**Notes:**



**Day 8 – Scripture for the Day - 15 minutes**

**Team:**

**Leader:**

**Bible verses:**

**Notes:**



**Day 9 – Scripture for the Day - 15 minutes**

**Team:**

**Leader:**

**Bible verses:**

**Notes:**



**Day 10 – Scripture for the Day - 15 minutes**

**Team:**

**Leader:**

**Bible verses:**

**Notes:**



**Day 11 – Scripture for the Day - 15 minutes**

**Team:**

**Leader:**

**Bible verses:**

**Notes:**



**Day 12 – Scripture for the Day - 15 minutes**

**Team:**

**Leader:**

**Bible verses:**

**Notes:**



**Day 13 – Scripture for the Day - 15 minutes**

**Team:**

**Leader:**

**Bible verses:**

**Notes:**



**Day 14 – Scripture for the Day - 15 minutes**

**Team:**

**Leader:**

**Bible verses:**

**Notes:**



**Day 15 – Scripture for the Day - 15 minutes**

**Team:**

**Leader:**

**Bible verses:**

**Notes:**

Blank page



## Appendix 1

### Master List of Pump Repair Tools

\*US or EU-made is recommended for these tools

#### Repair Tools by Pump Type

Specialized Tools	Mark II	Mark III	Bush	Afridev	Tara
India Mark II Tool Kit	x				
India Mark III Tool Kit		x			
Customized Multi-Tool				x	x
Pump Rod Clamp	kit	kit	x		
T-Handle Rod lifter	kit	kit	x		
Riser Main Vise	kit	kit	x		
* Pipe Lifting Clamp ("Pipe Elevator") and Straps	opt.	opt.	x		
* Tripod Top w/ 1-1/4" couplings	opt.	opt.	x		
1-1/4" x 10' GI pipe cut & threaded for tripod	opt.	opt.	x		
1-1/4" Floor Flanges for tripod leg ends	opt.	opt.	x		
* Block & Tackle, 3-Sheaves, 1000 lb Capacity for tripod	opt.	opt.	x		
75 Feet, 8 mm Braided Rope for tripod	opt.	opt.	x		
Slip Plate for 1-1/4" Pipe			x		
Pipe Vise, Portable, 2-1/2" capacity	opt.		x		
* Pipe Threader with 1-1/4" Die (verify NPT or BSPT thread)	Dkit		x		
* Pipe Threader with 2-1/2" Die		Dkit			
Pipe Cutter, 2-1/2" Capacity	x	x	x		
* Die and Tap, Metric set, M10x1.5 & M12x1.75	Dkit	Dkit	x		
* Die and Tap, SAE set, 7/16"x14 & 1/2"x13 (optional)	x		x		

#### Common-Use Tools (Installation typically requires more common-use tools than does pump repair.)

Tool Box, 26"	x	x	x	x	
* Pipe Wrench, two large (24" aluminum is preferred)	Dkit	Dkit	x		
* Pipe Wrench, two medium	Dkit	Dkit	x		opt.
* Combination Wrench Set 10mm - 19mm	x	x		x	
* Adjustable (Crescent) Wrench 10" or 12"	x		x	x	opt.
* Adjustable (Crescent) Wrench 6" or 8"	Dkit	Dkit	x	x	
* 10" Vise Grip Pliers, curved jaw	x	x	x	x	
Slip Joint Pliers, w/ Wire Cutter, 8"	x	x	x	x	
Long Nose Pliers, 6"	x	x	x	x	
Screwdriver, large flat blade	Dkit	Dkit	x	x	
Utility Knife W/Blades	x	x	x		
* 12" Metal Hack Saw	Dkit	Dkit	x	x	
* 12" Hack Saw Blades	x	x	x	x	
* Cold Chisel	x	x	x		
5-Meter Tape Measure	x	x	x	x	
Inspection Mirror	x	x	x	x	x
Metal File set - Round, Flat, Bastard with handles	Dkit	Dkit	x	x	
Thread File	x	x	x		
Hammer, 3-lb	Dkit	Dkit	x		
Wire Brush	Dkit	Dkit	x		
Shovel (for pad repair)	x	x	x	x	x
Concrete trowel (for pad repair)	x	x	x	x	x
Well Sounding Tool	x	x	x	x	x
Rope, safety perimeter 200' X 3/8"	Dkit	Dkit	x	x	x

Bucket, 5 gal	X	X	X	X	X
Hard Hats	X	X	X	X	X
Leather Gloves	X	X	X	X	X
Tarp on which to lay tools	X	X	X	X	

**Consumables – depends on types of pumps to be repaired**

Extra Piston Seals, O-Rings, Foot Valve Seats and Poppets
Coupling nuts and lock nuts (10 mm and 12 mm)
PVC Cement
PVC Couplings
Spare Parts “Kits” (if individual parts are not available)
Pipe dope (or Teflon Tape)
Chain Grease, small tube
Chlorine
Chain & Padlock to secure pump during chlorination
Blank Pump Repair Logs
Lifewater Water Quality Test Kit

**India Mark II Tool Kit (Standard)**



- |                         |                          |
|-------------------------|--------------------------|
| 1. Tool Box             | 7. Bearing Pressure Tool |
| 2. Pump Rod Vise        | 8. Pump Rod Lifter       |
| 3. Chain Support        | 9. Rod Coupler Spanner   |
| 4. Handle Axel Punch    | 10. Water Tank Lifter    |
| 5. Crank Spanners 17x19 | 11. T-Handle Lifter      |
| 6. C-Wrench Lifters     | 12. Rising Main Vise     |

**India Mark III Tool Kit (Standard)**



- Photo courtesy Shree SK Industries, www.skipumps.com
- |                          |                         |
|--------------------------|-------------------------|
| 1. Tool Box              | 8. Pump Rod Lifter      |
| 2. Pump Rod Vise         | 9. Rod Coupler Spanner  |
| 3. Chain Coupler Support | 10. Water Tank Lifter   |
| 4. Handle Axel Punch     | 11. Rising Main Vise    |
| 5. Crank Spanners 17x19  | 12. Check Valve Lifter  |
| 6. C-Wrench Pipe Lifters | 13. T-Handle Rod Lifter |
| 7. Bearing Pressing Tool |                         |

**Additional items included with SKI Deluxe Tool Kits ("Dkit")**

- |   |                        |
|---|------------------------|
| 3 Pipe Wrench (Mark II: 18" & 2@24" Mark III: 18", 24", 36")* | 2 File, flat and round |
| 1 Pipe Threader (Mark II: 1-1/4" Mark III: 2-1/2")*           | 1 Hack Saw w/ 5 Blades |
| 1 Tap handle w/ 12mmx1.75 taps*                               | 1 Ball Peen Hammer     |
| 1 Die handle w/ 12mm x 1.75 die*                              | 1 Wire Brush           |
| 2 Screw Driver, flat & Phillips                               | 1 Oil Can              |
| 2 Open-end Wrench, 17mm & 19 mm                               | 2 Tub Grease           |
| 1 Adjustable Wrench   | 2 Thin rope            |

\*The quality of these Indian or Chinese-made tools may be very poor.

## Appendix 2

### Well Disinfection Formulas

The math involved in calculating chlorine concentrations is valuable to know for situations that do not fit the “Table Method” described in the Well Disinfection lesson. The Formula Method involves measurements of the well and two calculations:

1. The volume of water in the casing and the gravel pack.
2. The amount of chlorine needed depending on the concentration of the chlorine source.

The following paragraphs describe these calculations in detail.

#### 1. Calculating Well Volume

The volume of water in the casing and gravel pack is found by the formula,  $V = \pi R^2 H$ ; where V is volume in liters,  $\pi$  represents pi (3.14), R is the radius of the well casing in millimeters (radius is the diameter divided by 2), and H is the depth of water in the well in meters (distance from the bottom of the well to the top of the water). Divide the result by 1,000 to convert cubic milliliters to liters. To calculate the water in the “annular space” between the well casing and the borehole wall, use the same volume formula. For radius, use  $\frac{1}{2}$  of the borehole diameter and for height use the same water column height as for the casing volume. [The borehole should normally be about 50 mm (2”) greater in diameter than the well casing, otherwise the gravel pack will not be very effective.] Then subtract the well casing volume from the total borehole volume. Multiply the result by 30% to account for the porosity of the gravel pack. Finally, add the casing volume to the adjusted annular space volume. This is the total volume of water in the well that needs to be disinfected.

The following table gives well volumes in liters per meter for different casing diameters. A 50mm thick gravel pack is assumed.

Casing Diameter	75mm (3")	100mm (4")	125mm (5")	150mm (6")
Well volume: liters per meter	6.8	10.8	15.8	21.8

**A sample volume calculation:** A 100 mm diameter casing ( $D_c$ ) is in a 150 mm borehole ( $D_b$ ) with a good gravel pack. The well is 30 meters deep ( $H_d$ ) and the distance from the surface to the static water level is 15 meters ( $H_w$ ). (All results are rounded off.)

The well casing volume is:  $V_c = \pi * (D_c/2)^2 * (H_d - H_w) / 1000$   
 $V_c = 3.14 * 50^2 * (30 - 15) / 1000 = 122$  liters

The total borehole volume (including the casing) is:  $V_b = \pi * (D_b/2)^2 * (H_d - H_w) / 1000$   
 $V_b = 3.14 * 75^2 * (30 - 15) / 1000 = 265$  liters.

The annular space volume (Va) is Vb-Vc or 265 liters minus 122 liters = 143 liters. Only 30% annular space is filled with the water; the rest is gravel. So the water volume in the annular space is  $V_a \times 0.3 = 143 \times 0.3 = 43$  liters.

The total volume of water in the well (Vw) is the casing (Vc) plus the adjusted annular space (Va);  $V_w = V_c + V_a = 122 + 43 = 165$  liters.

## 2. Calculating Chlorine Amount

The amount of chlorine to add depends on the concentration of the chlorine source. Chlorine is commonly available as dilute laundry bleach (3.5% to 5% chlorine) or as calcium hypochlorite powder used for drinking water treatment (typically 70% chlorine). Chlorine is unstable (and dangerous in high concentrations) so what might have come from the factory as a 5% solution could degrade to 3.5% after a year or so.

**A sample concentration calculation:** We calculated the volume of water to disinfect; now we need to add the right amount of chlorine to get a chlorine concentration of 250 mg/l in the well. The source of chlorine we have is laundry bleach in a bottle that looks like it has been on the store shelf for a long time. So we will assume that it is only 3.5% chlorine.

The formula for working with concentrations is  $V \cdot C = V_w \cdot C_w$ . The volume of bleach to add (V) is what we want to find out and we know the concentration (C) of that bleach (3.5%), the volume of water in the well (Vw) and the concentration in the well (Cw) that we want to reach.

Rearranging the formula gives  $V = V_w \cdot (C_w / C)$  or

$$V = 165 \text{ liters} \cdot 0.00025 / 0.035 = 165 \cdot .007 = 1.2 \text{ liters.}$$

[250 mg/liter is the same as 250 parts per million, then  $250 / 1,000,000 = 0.00025$  and 3.5%, or 3.5 parts per hundred, is  $35 / 100 = 0.035$ ].

The final result from this example of the “high precision” method is 1.2 liters of 3.5% bleach added to 165 liters of water in the well.

**Another sample concentration calculation:** This example uses the same well as before, but the source of chlorine is calcium hypochlorite powder. The desired chlorine concentration in the well (Cw) is still 250 mg/liter, or 0.25 grams per liter. At a source concentration (C) of 70%, the calcium hypochlorite powder has 0.7 grams of chlorine per gram of powder ( $70 / 100 = 0.7$ ). Using the concentration formula,  $V = V_w \cdot (C_w / C)$  the calculation is  $V = 165 \text{ liters} \cdot 0.25 / 0.7 = 165 \cdot 0.36 = 59$  grams. A tablespoon of calcium hypochlorite powder weighs about 12 grams. So in this example, we would dissolve 5 tablespoons ( $59 / 12 = 4.9$ ) of calcium hypochlorite powder in a bucket of water and pour that water into the well before installing the pump.

	Casing Diameter			
Disinfection Rate	75mm (3")	100 mm (4")	125 mm (5")	150 mm (6")
Grams of 70% powdered Chlorine per meter	2.4	3.9	5.6	7.8

**Appendix 3**
**HAND PUMP REPAIR RECORD**

Repair date (D/M/Y): \_\_\_\_\_

Village name and location: \_\_\_\_\_

GPS coordinates: \_\_\_\_\_

Well number or other designation: \_\_\_\_\_ Ownership: \_\_\_\_\_

Permission to repair well given by: \_\_\_\_\_ Title: \_\_\_\_\_

Number of people served by the well: \_\_\_\_\_ Number of families served: \_\_\_\_\_

Date installed: \_\_\_\_\_ Installed by: \_\_\_\_\_

 Is this a:  Borehole? or a  Hand-dug well? Casing or well diameter: \_\_\_\_\_

Total depth of well: \_\_\_\_\_ Depth to water (static level): \_\_\_\_\_

How much seasonal fluctuation? \_\_\_\_\_ meters Highest month: \_\_\_\_\_ Lowest month: \_\_\_\_\_

Type of hand pump: \_\_\_\_\_ Depth of pump intake: \_\_\_\_\_

Is there water in the well? Yes / No When was the pump last working? \_\_

Summary of this pump's repair history:

---



---



---

**Pump Performance Test results:**

Before repair: 40-Stroke Pump Test = \_\_\_\_\_ liters      5 minute Leak Test = \_\_\_\_\_ strokes

After repair: 40-Stroke Pump Test = \_\_\_\_\_ liters      5 minute Leak Test = \_\_\_\_\_ strokes

Describe all repair work completed:

---



---



---

Chlorine used: \_\_\_\_\_ liters at \_\_\_\_\_%      Pump locked? Yes / No      Instructions given? Yes / No

Was water quality tested: Before repair? Yes / No After repair? Yes / No (Attach any test results)

**Pump Repair Cost Information:**

Time spent repairing this pump: \_\_\_\_\_ hours      Number of trips: \_\_\_\_\_      Travel time: \_\_\_\_\_ hours

List all parts used: \_\_\_\_\_

List all expenses: \_\_\_\_\_

Other notes and comments:

---



---



---

Record completed by: \_\_\_\_\_ Signed: \_\_\_\_\_

 Copy of Repair Record given to:  Village Water Committee  Supervisor

 Government

Blank page



## Appendix 4

### Well Cleanout Tool Fabrication Instructions

#### Overview

When a hand pump has been removed from a borehole, and the borehole is left open, it is common for children to drop rocks into the hole. This makes a very intriguing sound but renders the well unusable. A tool is needed to remove these rocks without having to re-drill the well.

The Lifewater Well Cleanout Tool consists of a meter length of steel pipe in which there is a plunger and a series of overlapping shelves. The pipe is heavy enough to rest on the rocks at the bottom of the well when the plunger is pulled up by a rope. Rocks and sand are lifted up by the sucking action caused by the plunger and when they fall back they rest on the shelves. In addition, there are a series of small “fingers” around the bottom of the pipe that trap larger rocks. If the rocks extend above the water table, as is often the case, then pouring a bucket of water into the well while the cleanout tool is in place is enough to allow several strokes of the plunger before the water filters through the rocks.



1. Complete well Cleanout tool. 2. Detail of the bottom showing shelves and “fingers.”
3. Rocks trapped by the “fingers.” 4. Components of the plunger.
5. Detail of the top showing plunger assembly and the notch for emptying rocks.

# WELL CLEAN-OUT TOOL

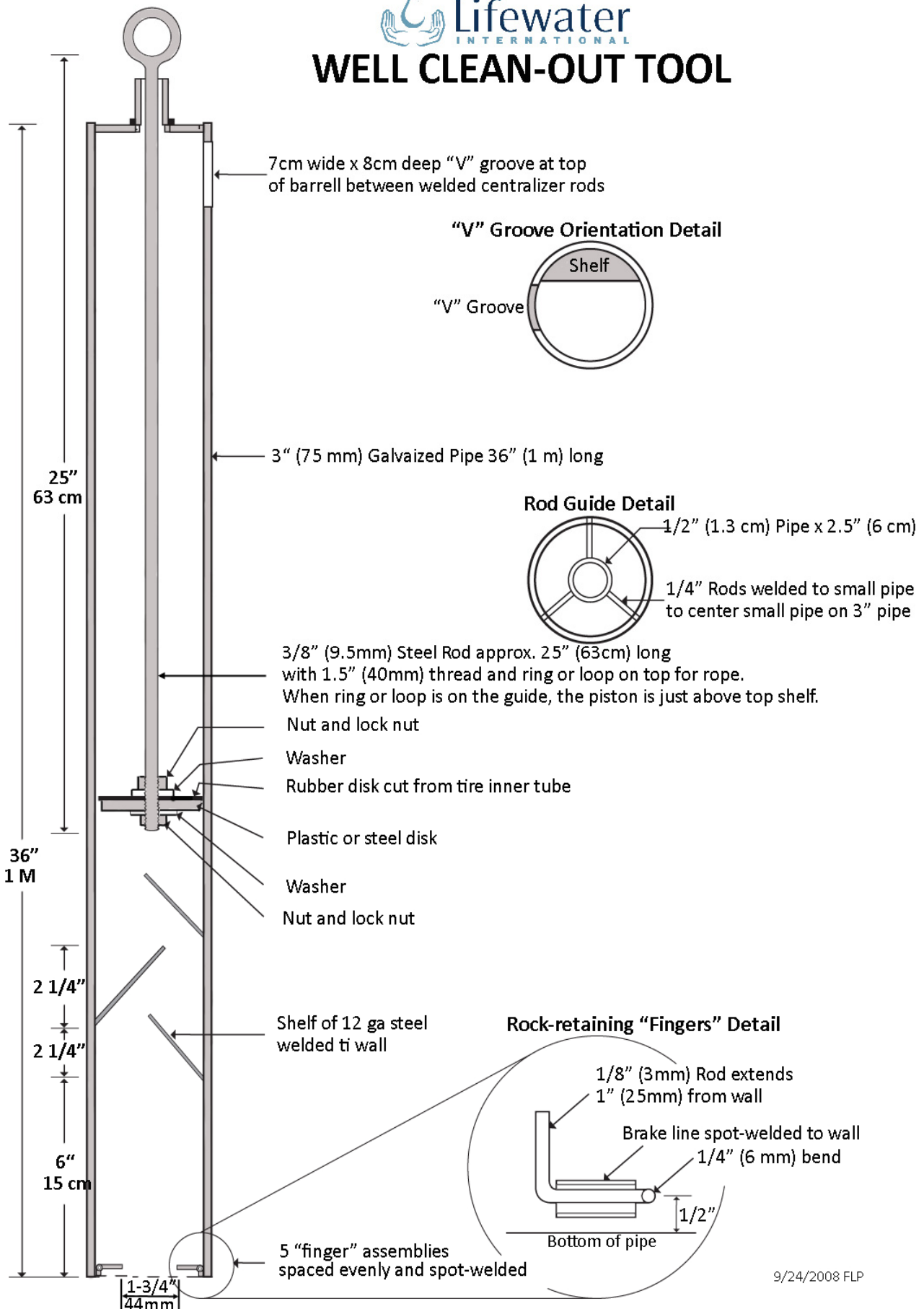

9/24/2008 FLP



### Materials

3" (75 mm) dia. Galvanized water pipe	3 feet (1 M)
3/8" (10 mm) rod	28 inches (710 mm)
1/2" (12 mm) galvanized water pipe	3 inches (75mm)
Approx 1/4" (6 mm) rod	5 (130 mm)
1/4" (6 mm) brake line	3 inches (75 mm)
12-16 gauge galvanized wire	12 inches (305 mm)
10-12 gauge (2-3 mm) steel plate, 3"x3"	4 pieces
Nuts for 3/8" (10 mm) rod	2 pieces
Washers for 3/8" (10 mm) rod	2 pieces
Truck tube cut 3" (75 mm) dia. round	1 piece

### Tools

Arc welder	Tubing cutter
3/32 inch (thin) welding rod	Bench Vise
Hacksaw	Hammer
Wrenches for nuts	Drill motor with drill bit equal to rod diameter
Threader for rod	Drawing compass for circle
Angle grinder	File (half-round is best)
Wire cutter	

### Fabrication Details

**Barrel:** Cut the 1-meter length of pipe with a hacksaw or pipe cutter, filing off any inside sharp edges. Using a hacksaw, cut a "V" notch at one end of the pipe that is 70 mm between the top of the "V" to where the cuts join at the bottom of the "V" and 80 mm in from the end of the pipe as shown in the illustration. Smooth the inside and outside edges of the cuts with a file.

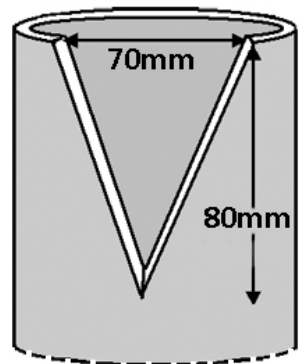

The best pipe to use is heavy gauge galvanized water pipe. This typically has a wall thickness of approximately 1/4-inch (6 mm). Thinner-walled pipe can be used, but it has to be made longer so that it will be heavy enough. If the barrel is too light, then it will be lifted off of the rocks when the plunger is pulled. If a longer barrel is used, then the plunger rod also needs to be lengthened (taking care that it does not hit the upper shelf).

**Shelves:** Use the template to the left to cut the three shelves out of 10- or 12-gauge steel plate. Grind or file as necessary to create a fairly snug fit at 45 degrees inside the pipe. This template is for 3-inch galvanized pipe.

If working with a different pipe diameter, make a new shelf template by cutting a spare piece of the pipe at a 45 degree angle and filing the inside edges smooth. Lay the 45 degree side on a piece of the 10- or 12-gauge steel plate as shown in the sketch and draw or scribe around the inside onto the plate.

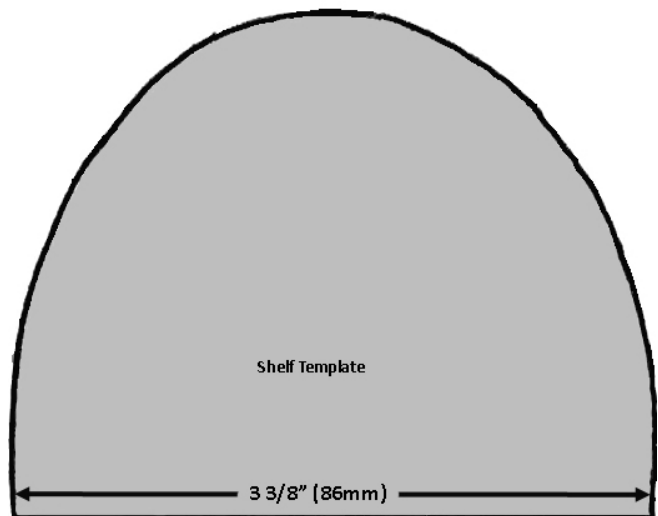

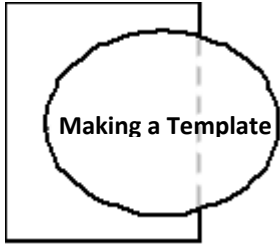

To weld the shelves, place the pipe in a bench vise with the “V” cut facing to the side and tack-weld the upper shelf inside the lower end of the tube, facing up about 10.5 inches (267 mm) from the bottom. Weld the next shelf on the opposite side about 8.25 inches (210 mm) from the bottom. The third shelf should be welded about 6 inches (150 mm) from the bottom. Each shelf has three weld spots, one at each top corner and one centered on the base. To facilitate welding of the shelves, the lower 12” (30 cm) of pipe may be cut off to give easier access. When the barrel pipe is welded together again, the outer weld bead must be ground flush with the pipe to prevent damage to the well screen.

**Rod Guide:** Cut 1/4-inch (6 mm) rod into approx 1.5 inch (38 mm) lengths with a hacksaw. Cut a piece of 1/2-inch (12 mm) water pipe about 3 inches (75mm) long. Ensure that the water pipe is cut squarely and the inside edges are filed smooth. On a flat surface, stand the water pipe on end then weld the three rod ends to the bottom, spaced evenly around the pipe. Finish welding on the bottom of the pipe to strengthen the weld. Place the guide on top of the upper end of the barrel (with the “V” cut), centered with two of the three legs at the edges of the “V.” Weld the rods thoroughly to the pipe then grind any protruding rods smooth with the edge of the barrel.

**Plunger Rod:** Thread one end of the rod about 1.5 inches (40 mm). Bend the other end around a 3/4-inch (18 mm) rod to create a loop at the end for the rope, centered on the rod with no gap between the end of the loop and the rod.

**Piston and Rubber Flap:** Cut the remaining steel plate into a circle 1/4-inch (6 mm) smaller than the inside of the 3-inch barrel, drilling a hole the size of the rod in the center. (A PVC disc at least 1/4” thick would also work in place of the steel disc). File the edges smooth. Cut the truck inner tube the exact diameter of the pipe with a hole in the center the same size as the rod. Notches or holes can be cut along the rim of the plunger so that it will drop easier.

**Rock-Retaining Fingers:** Cut 1/4-inch (6 mm) brake line into 5/8-inch (16 mm) lengths, reaming flashing or roughness from the cut ends with a reaming tool until smooth. Cut galvanized wire into 2 inch (50 mm) lengths. Clamp each wire in a vise with 1/4” protruding and bend 90 degrees from the shaft. Slide a piece of the 1/4” brake line to the bend, placing the remaining end into a vise. Using a pair of fence pliers or narrow pliers, bend the piece with the brake line on it so the resulting bend is 90 degrees from each of the other runs. Each of the fingers should be bent in the same way so they fit in sequence inside the pipe (see photo on previous page). After ensuring the fingers rotate smoothly in their sleeves, draw or scribe a line 1/2” inside the bottom of the barrel. Divide the inside circumference by 5 and mark the inside at that interval, making 5 equal spaces. One-at-a-time, place the sleeve on the line parallel to the bottom and at the 1/5th mark. Using a thin welding rod or wire, start a puddle just under the tube and move just to the tube, quitting the weld as it contacts the tube. Be careful not to burn through the thin-walled tube. Repeat welding the remaining 4 tubes then check for free movement of the wire.

**Install the Rod and Piston:** Insert the rod just through the top guide, thread a nut all of the way onto the threaded portion of the rod, and tighten to the unthreaded surface. Place a washer, the inner tube, the round plate, another washer and then a second nut on the rod and tighten until just snug. Do not over-tighten as this will deform the rubber. Peen the thread or add a jam nut on the bottom to prevent loosening. Check smooth functioning of the piston assembly and adjust if necessary.

**Operation:** With a 3/8” (9 mm) braided rope securely tied to the loop in the piston rod, the cleanout tool is ready to use. It is most easily operated using a tripod and single pulley assembly when significant rock removal is necessary. Each well takes some experimentation to achieve optimum performance. Pull the plunger up quickly to get maximum suction. Don’t pull the plunger more than three or four times before bringing the tool to the surface. Otherwise, the tool can settle into the rocks and become stuck.

## Appendix 5

### Bailer Construction

A “bailer” is a length of PVC pipe, usually about a meter long, with a diameter that easily fits into the well casing. It is used to “develop” the well by removing silt and sand that remains after the well is drilled or that may have accumulated in the well over time. The bailer is typically raised and lowered on a rope using a tripod and pulley. The motion of the bailer as it moves up and down under water creates a “surge” through the well screen that helps to improve well yield.

At the bottom of the bailer is a one-way valve and at the top is an attachment point for a rope. As the bailer is lowered into the well, the one-way valve allows it to fill with water. When the bailer is raised, the valve holds the water. The bailer is brought to the surface and tipped upside down to empty it.

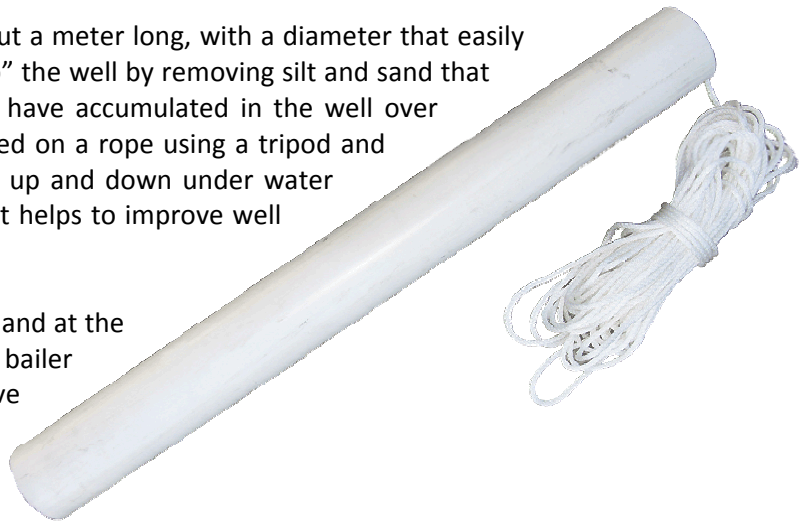

Bailers can be purchased from drilling supply companies, but they are relatively easy to make. There are several different ways to make the one-way valve. One example is described below:

**Step 1.** Cut a disk out of plastic with a diameter that just fits into the bailer. (A flattened piece of PVC casing is a good material to use.) Cut a hole offset from the center of the disk that is about half the diameter of the disk. For a 3-inch (77 mm) diameter bailer, the disk should be 76 mm in diameter and the hole around 38-40 mm.

**Step 2.** Cut a disk out of a piece of heavy truck tire inner tube or similar rubber. This “flapper valve” needs to be flexible but thick enough so that the weight of the water can’t push it through the hole in the plastic disk. The flapper should be around 3/4<sup>th</sup> the diameter of the plastic disk; that would be 58-60 mm for a 3-inch bailer. It should be larger than the hole by at least 5 mm on all sides.

**Step 3.** Cut a shape out of PVC as shown and drill two holes in it slightly smaller than the diameter of a small wood or metal screw. Stainless steel screws are best since they will not rust like regular wood screws.



**Step 4.** Assemble the pieces as shown.

**Step 5.** Cut off two rings about 10-15 mm wide from the same diameter of PVC pipe that you are using for the bailer. Cut out a section from each ring about 30 mm wide. You should be able to compress the rings and slide them into the bailer so they fit snugly. These rings will be the “keepers” for the disk and flapper assembly.

**Step 6.** Insert into the bailer one ring, the disk assembly (screw heads pointing out), and the second ring. Then remove them to make adjustments needed to ensure a snug fit. Once a good fit is obtained, put PVC cement on the inside of the pipe where the first ring will sit and then insert the first ring. Put a small amount of PVC on the end of the first ring, then press in the disk assembly. Finally, glue and insert the second ring to hold the disk tightly. The bottom edge of the second ring should be even with the bottom of the bailer.

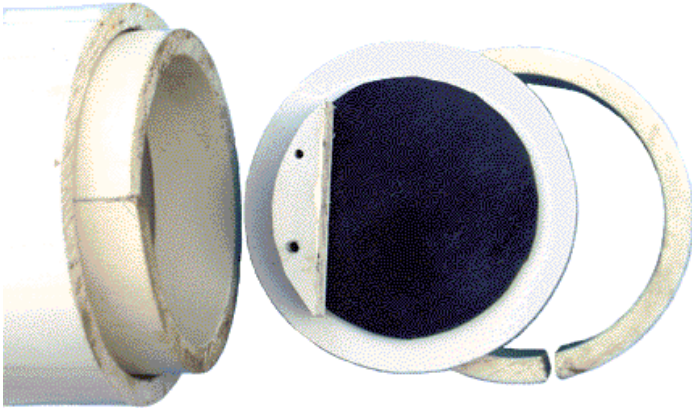

Once a good fit is obtained, put PVC cement on the inside of the pipe where the first ring will sit and then insert the first ring. Put a small amount of PVC on the end of the first ring, then press in the disk assembly. Finally, glue and insert the second ring to hold the disk tightly. The bottom edge of the second ring should be even with the bottom of the bailer.



The bottom end of the bailer should look like this. Putting the screw heads on the outside makes it possible to replace the rubber flapper valve if it wears out. Round-off the outer edge of the bailer bottom so that it will not cause damage to the slots in the well screen.

**Step 7.** There are two ways to make an attachment point for the rope. The easiest is to drill two holes on opposite sides of the bailer about 20 mm below the top. Run a stiff wire through the holes to form a loop and wrap the ends of the wire around the loop, as shown. Heavy-wall PVC pipe is shown in these illustrations. If thin PVC pipe is used, then the top of the bailer must be reinforced with a PVC ring similar to those used in the bailer bottom.



Another way to make the rope attachment is to cut a PVC ring and drill two holes through it into which a steel rod is inserted. When this assembly is glued into the top of the bailer it provides a secure attachment point that will not damage the well screen.

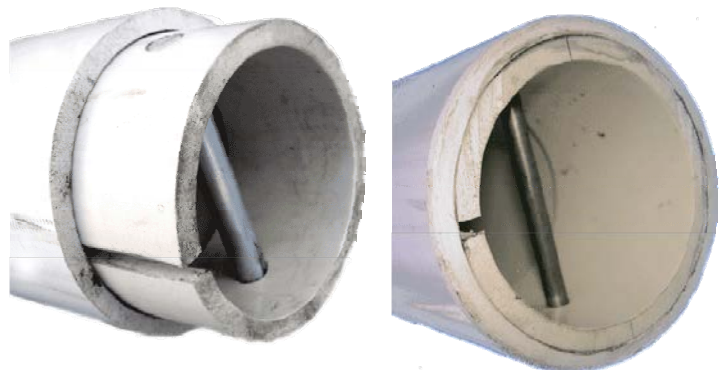

## Appendix 6

### Pump Repair Training Materials

The following is a compilation of “Materials” from each lesson in this manual:

Lesson	Materials
All	Course manual for each student (translated if needed)
All	Name Tags & Holders (color code by team)
All	Blank “Flipchart” approx 2’x3’ (newsprint works, but may bleed through)
All	Masking tape, pins, or binder clips to hold up Flipchart & posters
All	Markers for Flipcharts and dry-erase for white boards
All	Pens or pencils for students (encourage writing in their manuals)
1.1	Blank 8.5x11 paper for “expectations”
1.3	Poster of Water Cycle
2.1	Poster of typical well components
2.2	Buckets of water
2.2	Clear plastic demo pump cylinder
2.2	A Mark II pump cylinder for each team, various styles
2.2	Poster of Cylinder Parts
2.2	Poster of Cylinder Operation
2.2	Pipe wrenches and adjustable wrenches to disassemble cylinders
2.3	Posters of pump types: Suction, Direct Action, Deep Well
3.1	Two lengths of threaded pipe and a coupling for each team
3.1	Tools in toolbox (see Master Tool List, Appendix 1)
3.3	One set of the “Ten Steps” for each team (see below)
3.4	Poster of Disinfection Table
3.4	Bottle of locally-obtained chlorine bleach.
3.6	Blank Hand Pump Repair Report forms
3.6	Poster of a completed Pump Repair Record
4.1	Poster of Afridev Pump



4.2	Poster of Afridev Cylinder
4.2	Afridev cylinder, if available
4.4	Poster of Mark II pump
4.4	A Mark II pump cylinder for each team
4.5	Sample fishing tools, multiple types.
4.5	Wrench, pump rod, and riser main as “fish.”
4.5	Mock wells – 4” PVC casing with a bottom cap and lashed to the side of a pickup truck.
4.6	1-1/4” riser main, unthreaded – about a meter length for each team
4.6	Pipe vise, pipe cutter, pipe threader (handle & 1-1/4” die), reamer or round file.
4.7	Pump rod, about a meter length for each team
4.7	Hack saw, threading die and handle, file, and pump rod clamp – for each team
5.1	Poster of broken and dirty pump pad
5.1	Poster of repaired pump pad
5.1	Cement, sand, and gravel in 1:2:3 ratio – each team should have 2-3 liters of cement and proportionate amounts sand and gravel to mix.
5.1	Buckets, shovels, and trowels for each team
5.1	Sufficient board or bricks to make concrete forms about 1 foot (30 cm) square
5.1	Water
5.2	Posters of Silted Casing, Rocks in the Casing, and Collapsed Casing.
5.2	Bailer and rope.
5.2	Bailer Materials: 3-inch PVC, PVC cement, rubber flap, pliers, heavy wire, screws, screwdriver, hacksaw
5.2	Well cleanout tool.
5.2	Bucket of silt and/or light sand
5.2	Bucket of rocks 2-6 cm in diameter
5.2	Mock wells – 4” PVC casing with a bottom cap and lashed to the side of a pickup truck.
5.4	Poster of Before & After Hand Dug Well.
Repairs	Hard hat and gloves for each student

Hand Pump Repair Steps – Cut out for sorting (Lesson 3.3)

**Briefly look at the hand pump for obvious clues to its condition.**

**Talk to the villagers about their hand pump.**

**Test the hand pump.**

**Ensure there is water in the well.**

**Disassemble the hand pump.**

**Discuss the problem with the villagers and what the repair will cost.**

**Repair the hand pump.**

**Replace the pump in the borehole.**

**Reinforce community ownership of the pump.**

**Learn from your experience.**

## ADDITIONAL TRAINING MATERIALS

Lifewater has developed facilitator aids that are continually being revised and updated. Following is a partial list of materials that are available upon request from the Lifewater office, [Info@Lifewater.org](mailto:Info@Lifewater.org):

- Poster-sized (24" x 36") illustrations from the manual in PDF format (see index below)
- Sample Daily class schedule
- Suggested lesson sequence
- Breaker and Trainer notes (only suitable for use at a training facility where various types faults can be introduced into the pumps)
- "Oral Exam" questions for final course review

### "Posters" for Hand Pump Repair Training (2'x3' PDF format)

Available on the Lifewater web site, <http://www.lifewater.org/training.aspx>

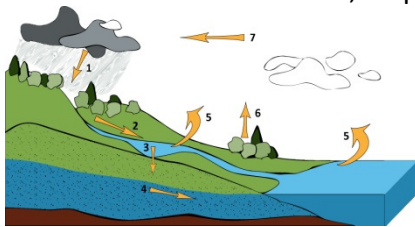

2 - Water Cycle

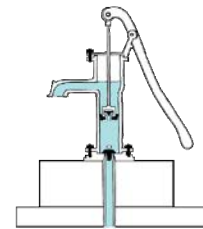

9 – Suction Pump

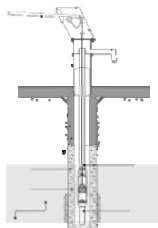

3 – Typical Well Components

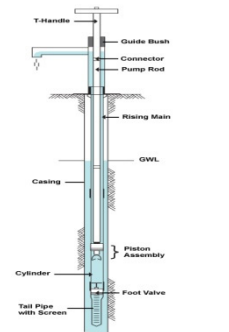

10 – Direct Action Pump

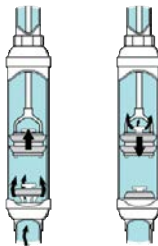

6 – Cylinder Operation

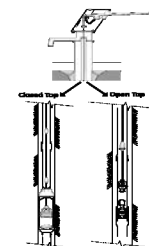

11 – Deep-Well Pumps

	Casing Diameter / Disinfection Rate	75mm (3")	100mm (4")	125mm (5")	150mm (6")
1	Liters of 3.5% liquid bleach per meter of water	0.05	0.08	0.11	0.16
2	Liters of 5% liquid bleach per meter of water	0.03	0.05	0.06	0.11
3	Teaspoons of 70% Powdered Chlorine per meter	0.21	0.33	0.48	0.86
4	Ounces of 70% powdered Chlorine per meter	2.4	3.9	5.8	7.0
5	Well volume: liters per meter	6.8	10.8	15.8	21.8
6	% Reduction if there is no gravel pack	33%	25%	20%	16%

T2 – Well Disinfection Table

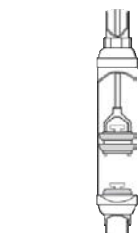

7 – Mark II Cylinder





**T3 – Repair Record**

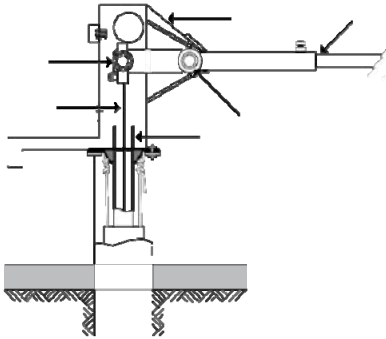

**16 – Afridev Head**



**17 – Afridev Cylinder**

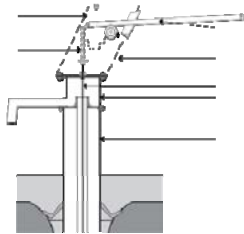

**19 – Mark II Head**

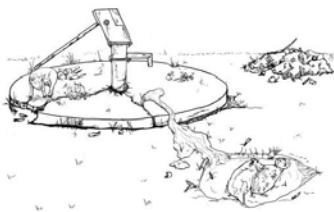

**31 – Bad Pump Pad**

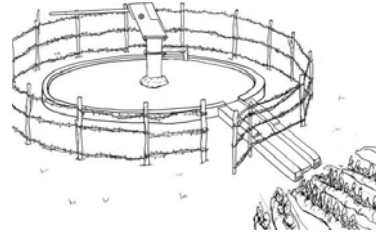

**32 – Good Pump Pad**

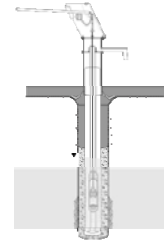

**34 – Silted Casing**

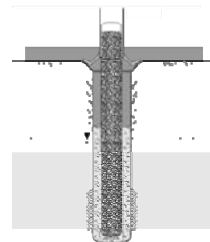

**35 – Rock-filled Casing**

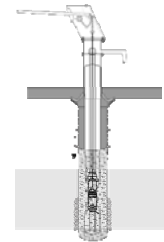

**36 – Collapsed Casing**

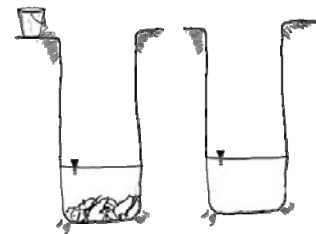

**39 – Hand-Dug Upgrade**

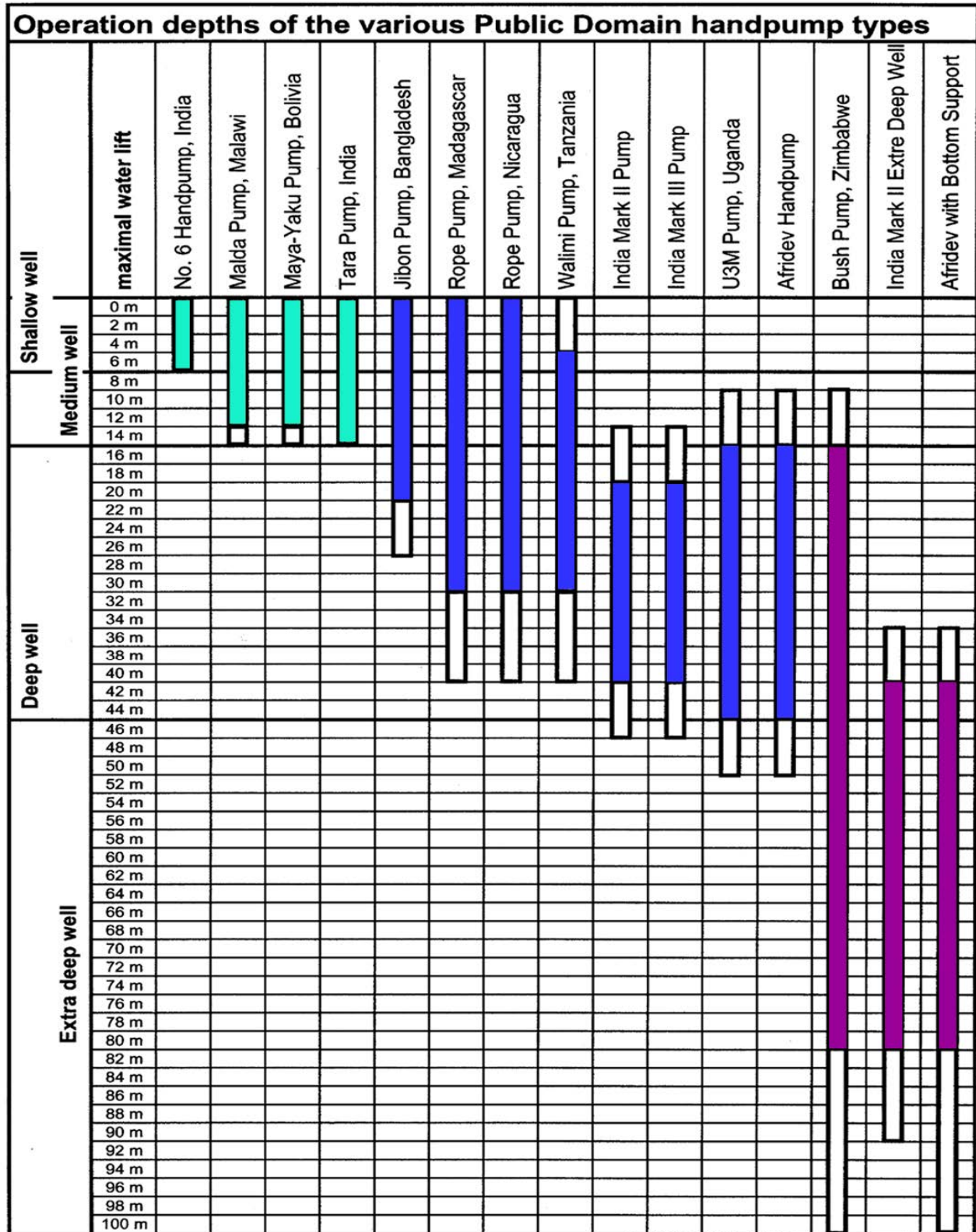

**Appendix 7**

Adapted from "Buyer's - and technology selection Guide for Public Domain Handpumps for Drinking Water"  
 Erpf, Karl 2004. SKAT Foundation, Switzerland



## Appendix 8

It is highly recommended that the following publication be included with the course materials in areas where Mark II pumps are encountered.

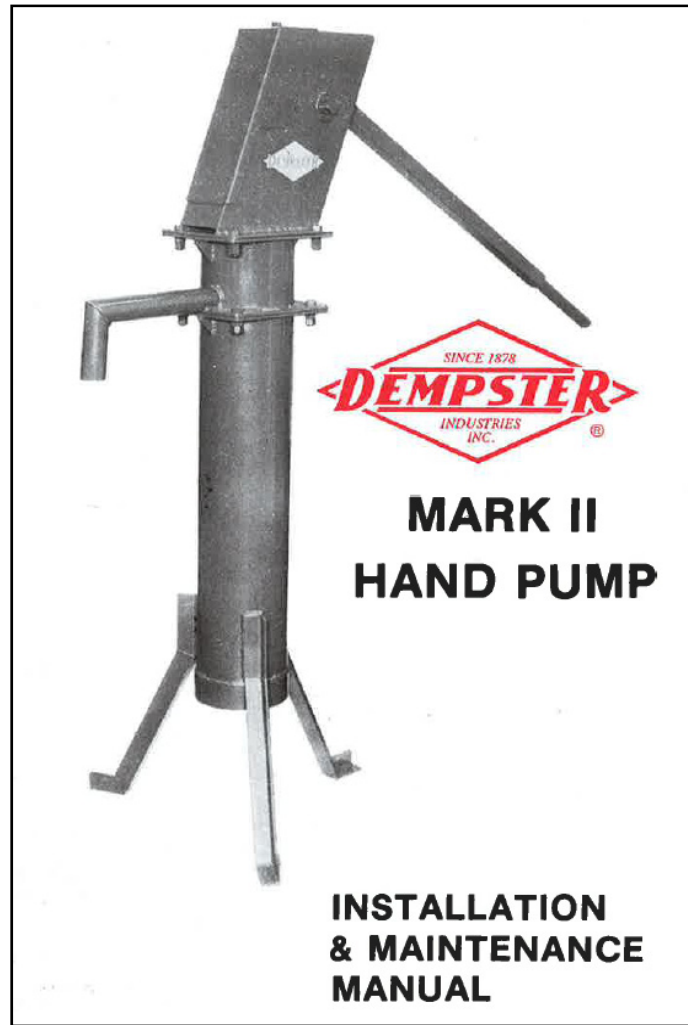

This example may be obtained from:

Dempster Industries, Inc.  
711 South 6<sup>th</sup> Street  
Beatrice, NB 68310  
800-777-0212

Other Mark II installation and maintenance manuals may be obtained from different manufacturers, most of which are located in India. Free online versions have not been found, but the Rural Water Supply Network publishes several excellent manuals at:  
[http://www.rwsn.ch/prarticle.2005-10-25.9856177177/prarticle.2005-10-26.2582788867/prarticle.2008-12-04.2105225472/prarticle\\_view](http://www.rwsn.ch/prarticle.2005-10-25.9856177177/prarticle.2005-10-26.2582788867/prarticle.2008-12-04.2105225472/prarticle_view).



## Appendix 9

It is highly recommended that the following publication be included with the course materials in areas where Afridev pumps are encountered.

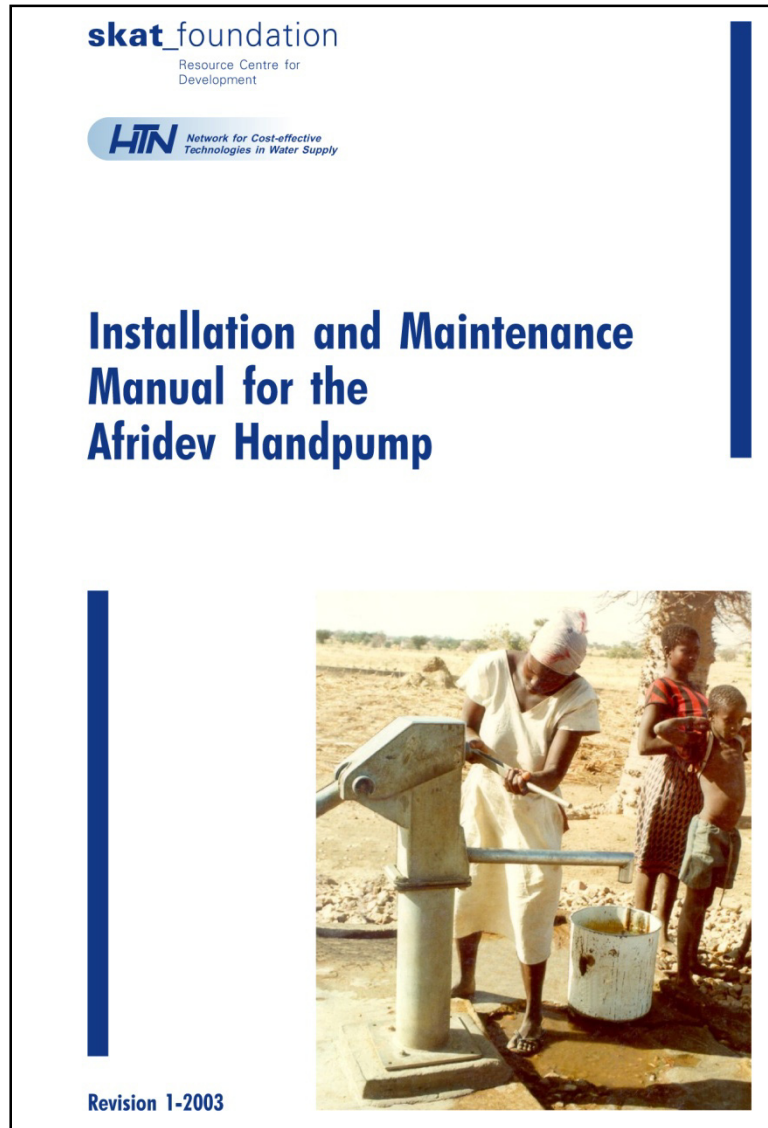

It may be obtained from:

Skat\_Foundation  
Vadianstrasse 42  
CH-9000 St. Gallen  
Switzerland  
Info@skat.ch

Or downloaded in PDF format from:

<http://www.rwsn.ch/documentation/skatdocumentation.2005-11-15.6036171875/file>